

rural
sanitation
technology
options

Y
1981

RURAL TECHNOLOGY SERIES

RURAL SANITATION

Technology Options

Based on Workshop to identify and appraise
Technology for Sanitary Latrines, Bio-gas
Plants and Smokeless Chulahs.

Delhi, May 1981

CONSORTIUM ON RURAL TECHNOLOGY
&
INSTITUTE OF SOCIAL STUDIES TRUST

November, 1981

RURAL SANITATION

Cover designed by:
Malika Viridi

Technology Options

Price Rs. 15/-

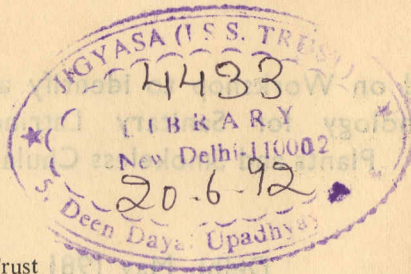

Published by
Institute of Social Studies Trust
M-1, Kanchenjunga,
18, Barakhamba Road,
New Delhi-110 001.

Printed in India by
Navchetan Press (P) Ltd.
at Navjeevan Printers
1-E/2 Jhandewalan Extension
New Delhi 110055

Preface

Sanitary latrines, safe drinking water, smokeless chulhas are all essential ingredients of the endeavour to raise the quality of life of our population especially women and children. Improvements in these fields are crucially dependant on proper technology which suits the physical, economic and cultural circumstances of different regions and communities.

This publication makes a positive and practical contribution in identifying the available technological options in this field and discusses their pros and cons. It will be of invaluable help to all those interested and engaged in rural development, particularly rural sanitation.

- 1. Mr. B. Patra
- 2. Mr. S.K. Gadi
- 3. T. Vijaynara
- (Reporters)

Members for Panel on Night Soil Disposal

- 1. Mr. Ranjan, NEERI
- 2. Mr. Jashbir, PRAD
- 3. Mr. Egnodwal, Ministry of Agriculture
- 4. Mr. San Dalal, UNICEF
- 5. Mr. Patra, Salaha International (Rapporteur)

Staff of ISS Trust who worked on this Report

- | | |
|--------------------|--|
| 1. Jayesh Banerjee | Research Assistant and Project Coordinator |
| 2. Aban N. Sinha | Research Assistant |
| 3. P.K. Nair | Stenographer |
| 4. Miss V. Sanyal | Stenographer |

Acknowledgements

Our thanks to all those listed below, without whose help and extra effort this report could not have been completed. Our special thanks to Dr. K.C. Khandelwal for sparing the time to go through and advise us on the draft report and to Shri Sita Ram Goel for helping us with the publication.

Members of the working group on Latrines for areas with High Water Table

- | | |
|---------------------------------|-------------------------------|
| 1 Mr. Narendra Verma | CBRI, Roorkee |
| 2 Mr. A. Raman | NEERI, Delhi |
| 3 Mr. B. Pathak | Sulabh International, Patna |
| 4 Mr. S.K. Gadi | P. H. Engg. Deptt., Allahabad |
| 5 T. Vijayendra
(Rapporteur) | PECCE, New Delhi |

Members for Panel on Night Soil Based Gas Plants

- 1 Mr. Raman, NEERI
- 2 Mr. Ibrahim, PRAD
- 3 Mr. Khandelwal, Ministry of Agriculture
- 4 Mr. Sam Dalal, UNICEF
- 5 Mr. Pathak, Sulabh International (Rapporteur)

Staff of ISS Trust who worked on this Report

- | | |
|---------------------|--|
| 1 Jayanti Banerjee | Research Assistant and Project
Co-ordinator |
| 2 Alope N. Jha | Research Assistant |
| 3 P.G. Nair | Stenographer |
| 4 Miss. V. Jayasree | Stenographer |

Table Of Contents

I	INTRODUCTION	1
	1 Background	
	2 Participation	
	3 Objective of the workshop	
	4 Proceedings	
II	FINDINGS AND SUGGESTIONS	5
III	SUMMARY OF DISCUSSIONS	9
	1 Sanitary Latrines	
	2 Report of the working group on Latrines in Regions of High Water Table	
	3 Bio-gas from Night-soil	
	4 Report of the technical panel on night-soil based gas-plants	
	5 Chulah	
	6 Methodology of Extension : Some view points and examples	
	7 General observations	
IV	ABSTRACTS OF PAPERS PREPARED FOR THE WORKSHOP	51
V	SELECTED PAPERS PRESENTED AT THE WORKSHOP	61
VI	LIST OF PARTICIPANTS	73
VII	SPECIFICATIONS AND COSTS	79

Abbreviations

CORT	Consortium on Rural Technology.
ISS	Institute of Social Studies Trust.
SI	Sulabh International.
NEERI	National Environmental Engineering Research Institute.
RPI	Regional Planning Institute.
SV	Safai Vidyalaya.
MGSN	Maharashtra Gandhi Smarak Nidhi.
KVIC	Khadi and Village Industries Commission.
TP	Thapar Polytechnic.
FF	Ford Foundation.
HUDCO	Housing and Urban Development Corporation.
PRAD	Planning and Research Action Division.
SSS	Sulabh Shauchalay Sansthan.
RCA	Research cum Action Project.
UNDP	United Nations Development Project.
CBRI	Central Building Research Institute
PECCE	Public Enterprises Centre for Continuing Education.
AFPRO	Action For Food Production.
UNICEF	United Nations International Childrens Education Fund.
NBO	National Buildings Organization.
HERL	Hyderabad Engineering Research Laboratories.
SFDA	Small Farmers Development Agency.
BDO	Block Development Officer.
VLW	Village Level Worker.
CART	Council for Advancement of Rural Technology.

I

Introduction

BACKGROUND

In the begining of 1981, organisations engaged in rural development in India formed a Consortium on Rural Technology (CORT) to initiate firm measures for developing and taking appropriate technology to the rural community.

At its first meeting (7th and 8th February, 1981), CORT decided to set up a number of technical panels each dealing with a specific item. Panels were formed on (i) Wind Mills, (2) Solar Cookers and Ovens, (3) Bio-gas, (4) Water Lifting/Drinking water Supply (Human and Animal Power), (5) Energy Plantation, (6) Rural Housing, (7) Rural Sanitation including Chulah, (8) Spinning and Weaving, (9) Leather Technology, (10) Rural Artisans (Blacksmithy, Carpentry, Pottery, Repair and Maintenance of Agricultural Tools, etc.).

The aims and objectives of these CORT panels are:

- (1) Appraise technology ready for field transfer.
- (2) Prepare detailed guidelines for
 - (a) Extension in the field
 - (b) Organise transfer of ready technology to the field
 - (c) Render the necessary assistance in order to ensure satisfactory transfer and dissemination.
- (3) Formulate proposals for modifications and adoption and field trial of research and development work.
- (4) Formulate proposals for future Research and Development for selected areas, to be submitted to the Department of Science and Technology;
- (5) Receive feed-back from extension organisations and transmit it to Research and Development Institutions.
- (6) Seek support for rural development with the above approach.

For effective functioning of these panels, CORT has named one Institute as the 'Focal Point' for servicing each technical panel.

Institute of Social Studies Trust (ISS), a voluntary non-profit research organisation was chosen as the focal point for the technical panel on sanitation including chulah. This was partly in recognition of two background papers, (1) Rural Sanitation—A Report on Village Latrines, (2) Cooking with Fire-wood: The Burning Issue, prepared by ISS for the CORT meeting in February, but mainly for ISS's wider concern for issues relating to women's development.

The members of the panel are:

- 1 Sulabh International
- 2 NEERI
- 3 R.P.I. (Regional Planning Institute)
- 4 Safai Vidyalaya
- 5 MGSN
- 6 KVIC
- 7 Thapar Polytechnic
- 8 Ms. Madhu Sarin (F.F.)
- 9 Mr. Gyan Sagar—U.P. Jal Nigam

This is the report of the first Workshop of the technical panel on Rural Sanitation organised by ISS and facilitated by a grant from Oxfam-U.K. The Workshop was held on 4th and 5th May, 1981 in New Delhi.

PARTICIPATION

Apart from the members of the panel, participants represented both official and non-official organisations engaged in significant work in the concerned fields. Research and Development Institutions, extension agencies, concerned government departments as well as relevant international organisations had been invited.

Out of 46 invitees, 42 participated. Sorely missed was Shri Ishwarbhai Patel, a pioneer in the field of Rural Sanitation, who was scheduled to participate but was unable finally to join the Workshop.

OBJECTIVE OF THE WORKSHOP

The ultimate object of the whole exercise is the improvement in the health and quality of life of the disadvantaged, specially the women and children in rural and urban India.

All these ideas of research and technology selection, etc. are after all means to an end. The Institute, which specialises in women's studies is convinced that as a rule women suffer more than men for lack of proper latrines, chulahs and energy requirements. Thus the quest for bio-gas is also of urgent concern to women, since collection of cooking fuel is one of the most time consuming and arduous jobs. And this has always been the responsibility of the women in the households-helped by the children.

Labour-time allocation studies have revealed that the children of the poor spend maximum time in collecting firewood and other sources of fuel. Thus, improving the energy resources and requirements in rural areas will also mean relieving children from household or income subsidising chores. A table presented at the National Conference on Women's Studies shows that among the landless, the women working in economically gainful activities work longer hours and constitute a higher percentage of the labour force. It is also seen that the intense period of women's labouring activity is directly related to her peak period of reproduction. The sex ratio of the landless is 100 points less than the national average i.e. there are 900 women for every 1000 men among the landless.

It is evident that the heavy physical burden on the rural women makes for higher mortality rates. Thus women should be the primary targets of any programme of improved sanitation, improved and efficient cooking devices and indigenous resources of energy like bio-gas.

Within the overall perspective, the specific agenda for this Workshop was as follows:

- 1 To review the technology available for sanitary latrines to be constructed in different parts of the country.
- 2 Identification of prevalent designs of bio-gas plants based on night soil for use in rural as well as urban areas.
- 3 Selection of designs and models of different chulahs for implementation in rural areas.

PROCEEDINGS

Mr. Radhakrishna, Chairman of CORT inaugurated the Workshop. He hoped that with the help of the 100 identified voluntary agencies and community polytechnics, it would soon be possible to start implementing the plans for technology transfer to selected villages in different parts of the country.

It was decided to review sanitary latrines first, followed by night-soil based gas plants and then the domestic chulah.

The group decided to work as a whole rather than split up, as all participants were interested in all the technologies, and no one wanted to miss any of it.

Shri Arunachalam, Chairman, Gandhi Nidhi and Shri B.K. Sharma, Joint Secretary, Ministry of Rural Reconstruction, addressed the morning session on the 2nd day.

The concluding session was addressed by Shri S.K. Handa, Deputy Education Adviser (T), Ministry of Education, and Smt. Phulrenu Guha, eminent social worker.

II

Findings and Suggestions

The main factors to be emphasised in any rural sanitation programme are:

- 1 Diminishing the risk to health caused by intestinal and helminthic infections,
- 2 The social dimension of liberating scavengers from a demeaning job,
- 3 Economic factors to be considered are:
 - (a) Saving of energy and recycling it to get fertilizer and gas.
 - (b) Decreasing consumption through more efficient use of available energy resources.
 - (c) The cost of installation and maintenance and the possibility of generating employment through the projects, are also important premises to a successful programme.

SANITARY LATRINES

It was obvious from the discussions among technical experts that no ideal fool-proof solution has yet been found for low cost sanitary disposal of human waste. Each system has some disadvantages/drawbacks either in the short-term or long-term sense. No final answers are available either to determine distance of pollution travel or fuel efficiency of a particular chulah. But on the basis of studies and research conducted so far, certain guidelines are available. Efforts to introduce intermediate technology are aimed at ameliorating conditions of rural life in keeping with modern civilisation—not perfecting them at one go. Therefore in the case of sanitary latrines, the idea put forward in the World Bank report assumes importance. The suggested system of sequential or incremental sanitation deserves attention and acceptance. It is only logical to go in for what is feasible at the moment and add improvements as time goes on. If this idea is accepted in principle, it becomes easy to recommend designs for specific areas and specific conditions. The World Bank report offers a set of related choices in the form of algorithms. This could be of great help to sanitation planners and field agencies too.

On the criteria of cost and simplicity and acceptable standard of hygiene, the Sopa Sandas popularised in Maharashtra can safely be recommended for most rural areas—specially where there is acute scarcity of water. The improved pit latrines being constructed by Thapar Polytechnic are also worth trying out in areas with similar soil etc. conditions. But this design needs certain modifications to improve their efficiency.

The single-pit pour flush latrine also falls in the same category of cost and simplicity. Only it pre-supposes a hard soil with deep sub-soil water level and a certain amount of water available for flushing. In Gujarat these have proved popular and effective.

The double-leaching pit latrines have a high element of efficiency of service in the long-run. Quite rightly it has been selected as *the* design to be adopted for conversion of dry latrines. However, for village homes where no latrines exist at all, the price of constructing a double-pit sanitary latrine is too high to-day. It is beyond the reach of *most* village people unless large subsidies are offered. (Sulabh International has designed some cheaper 2-pit pour flush latrines which could be tried out).

The same thing applies to the U.P. Jal Nigam Dwarf-septic tank model and to the aqua-privies. They all cost about Rs. 750 upto plinth level. With superstructure, the cost would be double. This type should be reserved as the 2nd step in most rural sanitary latrine systems.

With a normal septic tank the problem of cleaning remains: though it requires cleaning after long intervals this can only be done by scavengers unless mechanised systems are available.

The HUDCO experiment and other innovations to reduce costs without sacrificing essential components of the latrine—are promising. Efforts towards such ends should be a continuous process.

NIGHT-SOIL BASED GAS-PLANTS

Composting latrines like those developed in Scandinavia or the Vietnam model, which is very similar to the Gopuri design, do not seem to have found favour in India. Instead the consensus is to jump stages and go in for bio-gas plants based on night-soil. This is an ideal solution since human and other wastes are collected hygienically and recycled to yield gas as well as slurry for fertilizer.

Some gas plants attached to individual household latrines have been constructed in Maharashtra and Gujarat in the last decade or so, and work-

ing relatively successfully. Some plants based on night-soil from community latrines are in operation, but many of them depend on scavenger services, a system which cannot be allowed to continue in the interests of social justice.

Some designs for gas plants based on night-soil being fed directly from community latrines are ready for field trial. Extension agencies should collaborate with the research agencies to try these out.

It was decided that a study team should visit the plants at Nagpur, Pune, Gorakhpur, Lucknow, Trichur, Okhla and Gandhi Nagar where pilot plants have been set up. Their report could serve as a basis for the choice of a particular model for replication. Attempts should be made to design a fixed-dome 'Janta' type brick masonry bio-gas plant attached to a community latrine of the Sulabh pattern i.e. with water-seal pans as this would be ideal from the point of view of hygiene as well as economy.

DOMESTIC CHULAH

The three main designs presented at the Workshop are all technologically and economically feasible for transfer to the field. A comparative study to determine their relative efficiency in fuel conservation and saving of time could be undertaken. A study team was recommended to evaluate the user reaction and acceptance of the Chulah already constructed. Women should be questioned closely for their reactions to both chulahs and latrines.

GENERAL

It was found that one two-day session was not enough to cover all the ground. The technology review was achieved. Certain difficulties and drawbacks were identified and solutions discussed.

A follow up Workshop was visualised in six months time to evaluate the progress achieved in the intervening period and to discuss further steps for implementation of the programme.

Though methodology of extension was discussed, formulation of detailed guidelines and preparation of a manual had to be reserved for the future.

It was felt that a synthesis of official and non-official institutions, including technical institutions and voluntary organisations, is required. Also the effort towards transfer of technology has to be national rather than international. Rural people themselves must be motivated and persuaded to accept change and participate in the process of bringing it about.

It was hoped that the institutions and agencies brought together at the Workshop would keep closely in touch and work as a faculty, sharing technical know-how and other information, in order to achieve the common objective. ISS would do its share in facilitating this process.

Participants agreed that the Workshop was useful in bringing about an interchange of ideas and information which would help in achieving the common objective of rural development and environmental health through application of appropriate technology.

III

Summary Of Discussions

SANITARY LATRINES

At the outset it was stated that the twin functions of a sanitary latrine are the collection and disposal of human waste under hygienic conditions so that the risk to health in the way of intestinal and helminthic infections is minimised.

There are two main disposal systems available for rural areas in terms of technical, economic and social feasibility.

They are:

- 1 Leaching pits
- 2 Septic tanks

The merits and demerits of both were thoroughly discussed and it emerged that with either system, proper siting was crucial to avoid risk of pollution of ground water.

Risk of Pollution

The question of pollution; the distance it can travel both vertically and horizontally, in different soil conditions,—was raised with reference to each latrine design discussed. It was agreed that no final and empiric criteria have been established; investigations are in progress for both soil and water pollution. However, based on earlier studies, certain guidelines are available. It is advised by NEERI that a leaching pit should be sited not less than six metres downstream from a well or water-source and that the sub-soil water should be atleast one metre below the bottom of the pit. These distances can vary according to the type of soil. Pollution travels less in clayey soils and more in sandy soils. With longer use, the pores in the pit get filled up and the distance of pollution travel decreases.

Maturing Period For Sludge

With regard to all the leaching pit designs, close attention was paid to the period allowed for completion of the decomposition process or 'maturing'—before the pit is opened and the sludge handled. A one-year maturing period was suggested, the minimum acceptable being six-months. Emphasis was laid on scavenger-free systems. This is no problem with two-pit designs, but is a constraint in single pit privies.

Selection Of Appropriate Designs

Discussions centred on selection of latrine designs for regions with three types of soil and water conditions:—

- 1 Where the sub-soil water level is high i.e. 1.5 metres below the surface
- 2 Where sub-soil water level is low, but there is scarcity of water
- 3 Where sub-soil water is low and certain amount of water is available for flushing.

Selection of a suitable latrine design for areas with high sub-soil water proved a controversial issue.

A technical panel was formed to thrash out the problem. Their report is presented separately.

Next, attention was turned to those areas where sub-soil water is not a constraint, but scarcity of water is. This is true of areas of Maharashtra where Gandhi Smarak Nidhi has been doing pioneering and very effective work on rural sanitation for over 2 decades.

"Sopa Sandas" : a ventilated improved double pit latrine

More than 80,000 latrines have been installed since the inception of the programme. 85 per cent of these are of the 'Sopa' type; which is a ventilated double-pit privy with a tin flap instead of a water-seal trap. The components of the privy are (1) R.C.C. or stone slab with cement pan, (2) steep sloping pipe with a tin flap at the upper end, (3) rectangular displaced pit with partial honey comb brick-lining, (4) y-pipe to connect both pits and (5) a vent pipe to carry away odors from the pit. It was observed that the tin-flap prevents bad odor from entering the toilet and prevents the passage of flies etc. The flap gets worn-out after several years but it can easily be replaced at minimal cost.

According to rough estimates the cost of a double pit latrine is about

'SOPA' SANDAS

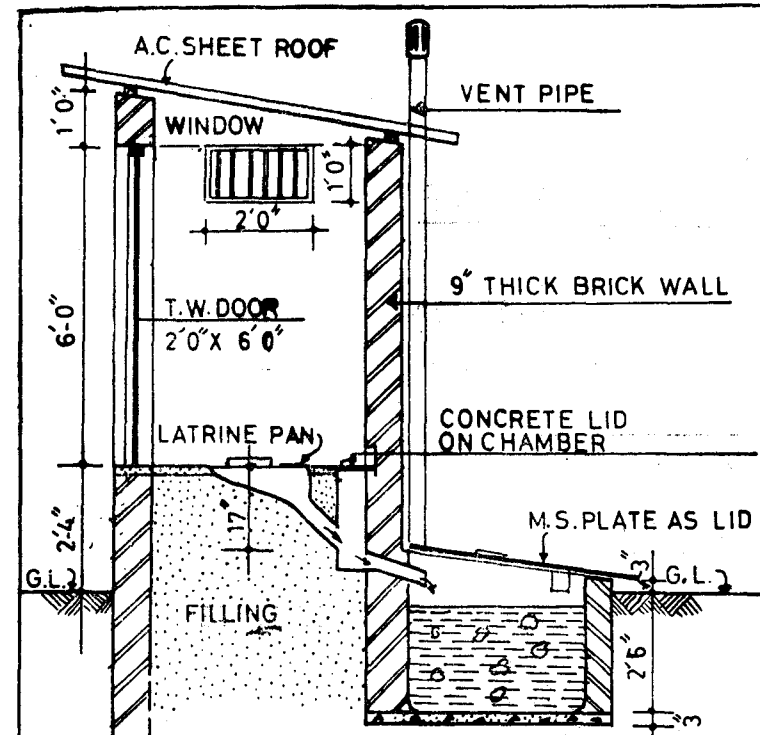

* SECTION
SCALE 1/2" = ONE FOOT

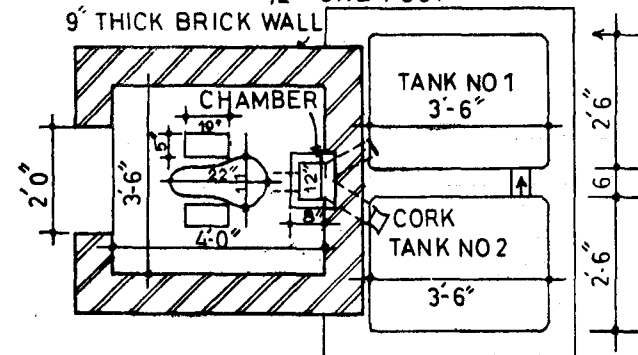

* PLAN
SCALE 1/2" = ONE FOOT

Y-TYPE SULABHA LATRINE

MAHARASTRA - GANDHI SMARK NIDHI GANDHI BAWAN
KOTHRUD PUNE- 411029

DRY PIT LATRINE

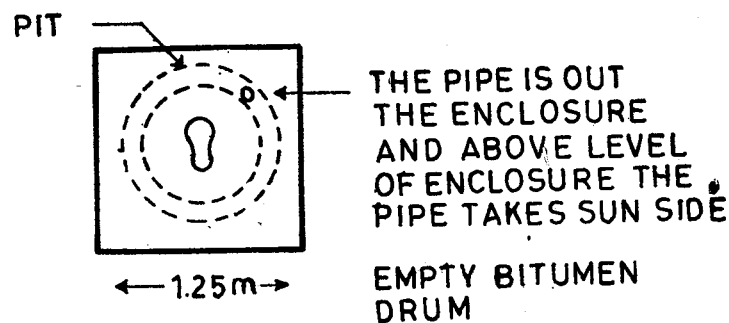
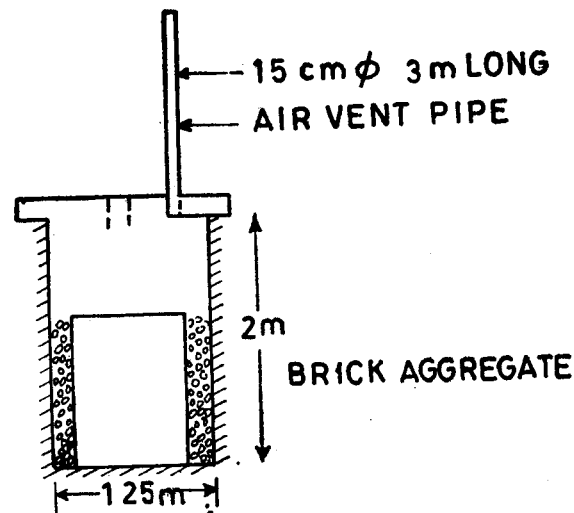

Estimate Rs. 125/- approx.

(2)

Rs. 400 upto plinth level. About Rs. 175 is being provided as a subsidy by the Maharashtra Government. Labour for digging and the reti (mud/sand) is provided by the householder, so these are not taken into account when quoting costs. Minus these items, the "Sopa Sandas" costs about Rs. 250. Single pit privies are built where constraints of funds and space warrant it and these cost Rs. 140 approximately. Pit dimensions are adjusted to suit individual households and specific conditions for a particular latrine.

If pits are maintained and handled according to specifications, the matured sludge is totally harmless and inoffensive. It can be extracted by the householder himself and yields valuable manure. (See Diagram 1 for details of design and the cost break-up).

VIP (Ventilated Improved Pit) latrine

Thapar Polytechnic, Patiala is a community polytechnic which is acting as an extension agency for rural technology since the last year and a half. They have constructed 38 latrines of the ventilated improved single-pit type based on a design developed in Rhodesia. Aerobic action takes place in the pit through a cycle provided by air-suction through the toilet seat and up the vent-pipe, which is warmed by the sun and therefore draws up the air. Rain water should not be allowed to enter. The toilet seat should be kept in the dark so as not to attract flies. The vent pipe should be at least 6" diameter.

It is claimed that there is no odor and the toilets are functioning well with no complaints so far. Since no flushing water is required, contents of the pit are relatively dry and therefore pollution travel is less. This is an important factor in Punjab, where most households have their own hand-pumps and therefore keeping greater distance between the toilet and well can become a problem.

The cost of this privy with superstructure is Rs. 900, without lining and upto plinth level it is Rs. 200. This is feasible in hard-clay soils, where the pit can be deep—6-9' and the privy will have a life of 5-7 years before emptying or cleaning is required.

In Punjab, the Block authorities have agreed to provide cement whose short supply and non-availability is otherwise a major constraint in the latrine construction programme. (Details of design and cost break-up in Diagram 2).

Two-pit leaching toilet with water-seal trap

The PRAD double-pit leaching toilet was developed in the late fifties.

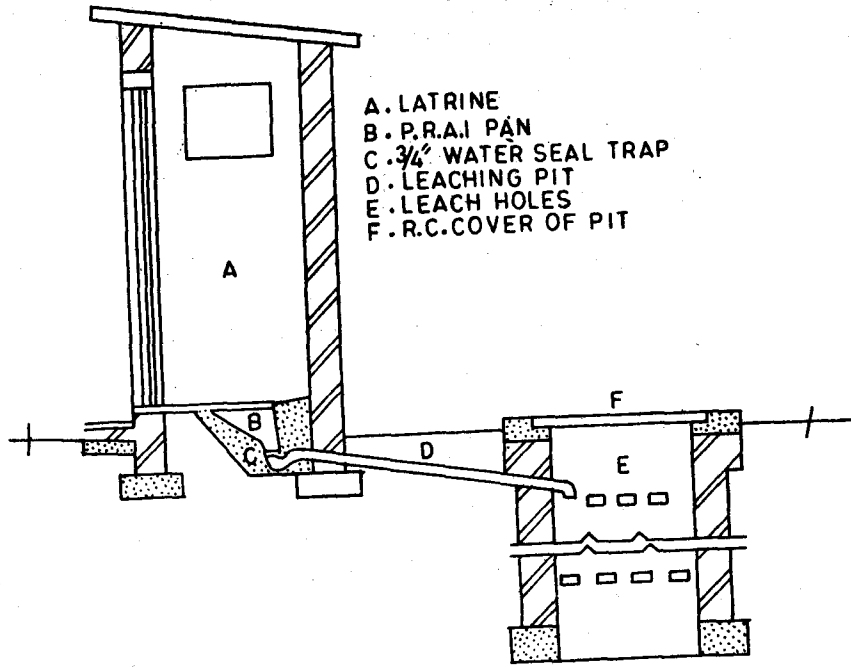

SECTIONAL ELEVATION

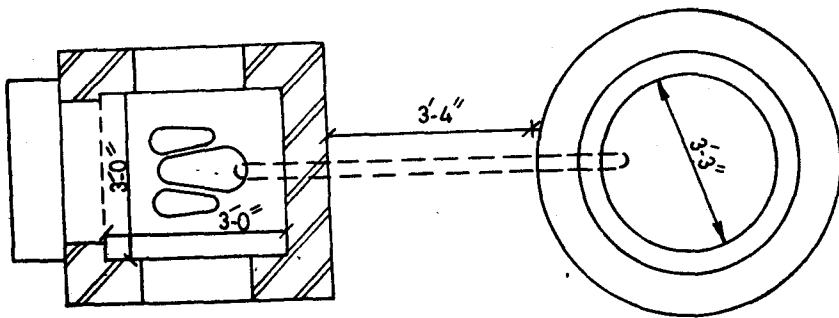

PLAN

P.R.A.I. TYPE LATRINE

(3)

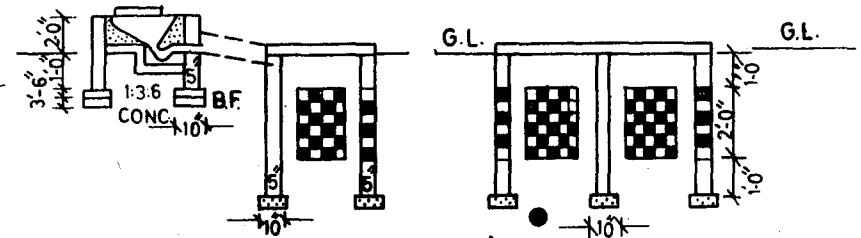

SECTION CD

SECTION FF

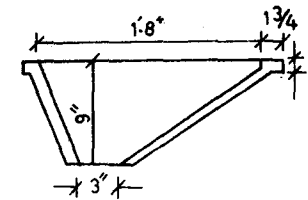
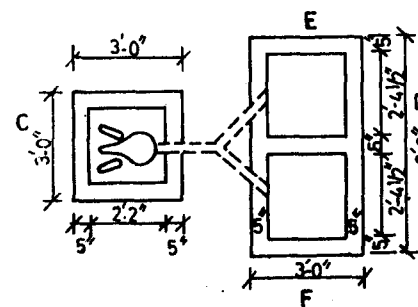

SECTION AB

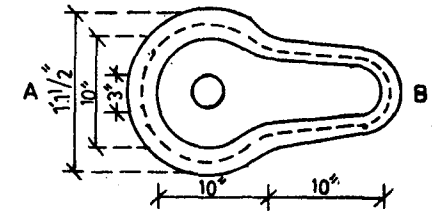

PLAN

PATTERN FOLLOWED BY SULABH SHOUCHALAYA
 SANSTHAN-PATNA

(4)

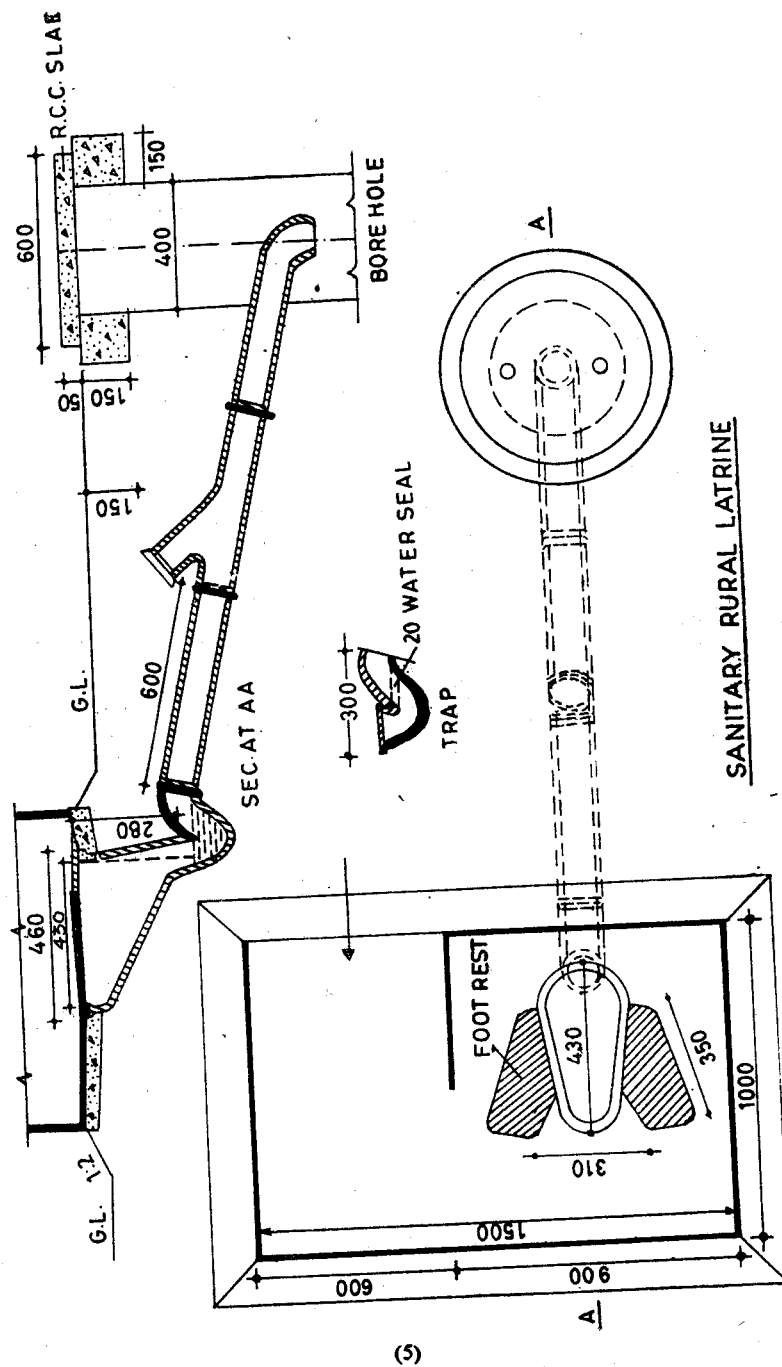

(5)

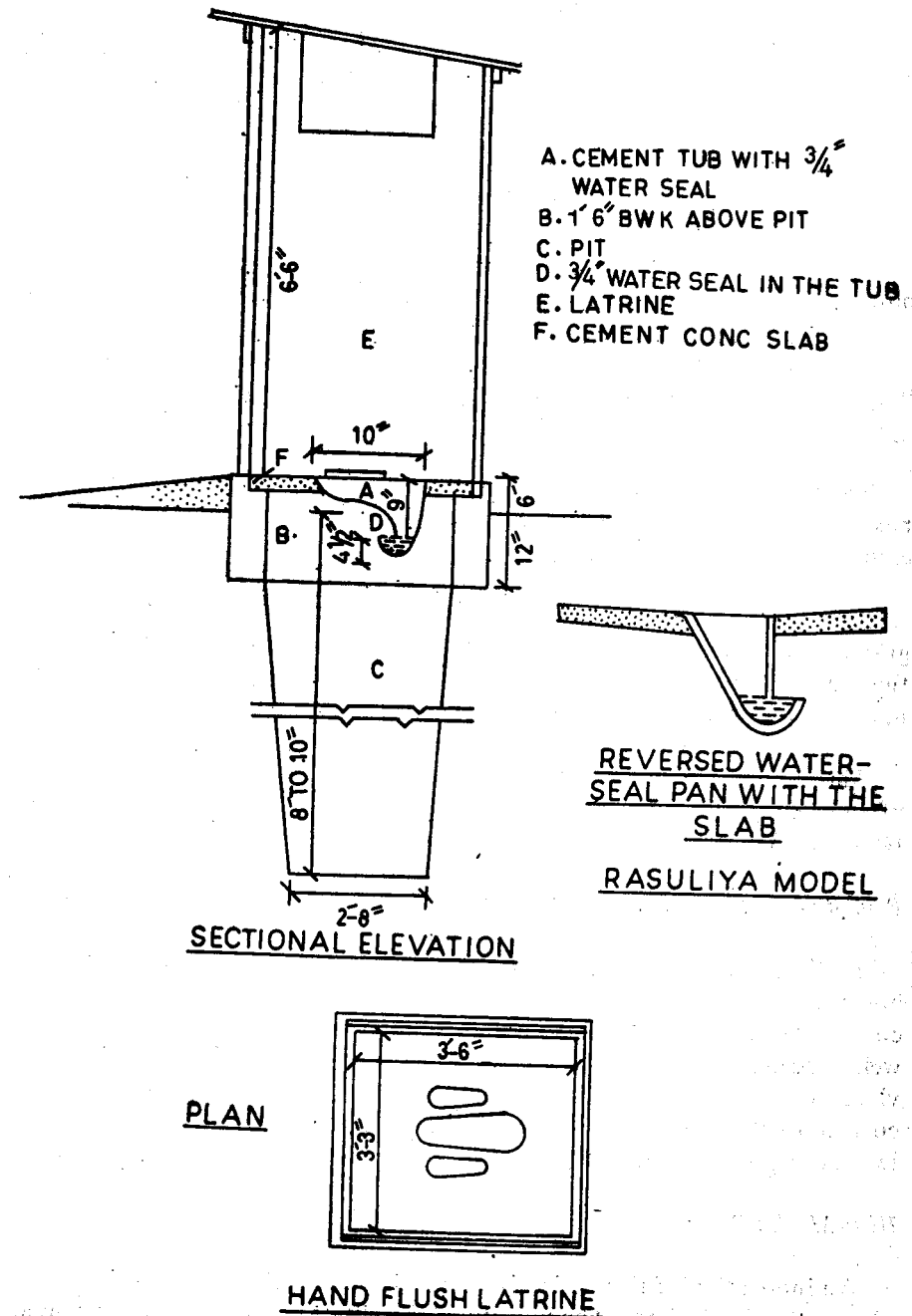

(6)

About 10,000 are said to have been installed in U.P. upto now. The PRAD-designed and manufactured pan, P-trap and Y-pipe are used for several other latrine designs also. In this model, a mosaic pan with a P-shaped water-seal trap is attached by a pipe to two displaced pits of one metre diameter and one metre depth, which are used in turn. The pits can be square or round, lined or unlined according to soil conditions and other factors of convenience.

In U.P. today the price of a twin-pit (lined) latrine is Rs. 410 upto the plinth level. A single-pit latrine is sometimes made and costs Rs. 268.

The latrines being constructed by the Sulabh Sauchalaya Sansthan of Patna (now known as Sulabh International) are very similar to the PRAD design. Their cost is about Rs. 750.

The NEERI design and the RCA model developed in the sixties are also basically the same and the cost too is similar with minor variations in different parts of the country.

This design has been selected as the best low-cost option for the programme of conversion of dry latrines. It is also being propagated under the UNDP Global Project for low-cost sanitation, as part of the International Water Supply and Sanitation decade.

This type of latrine presupposes low-level sub-soil water and availability of sufficient water for flushing. (Details of design and cost break-up in Diagrams 3,4,5).

Pour flush water-seal single-pit privy

Perhaps due to absence of any representative from Gujarat there was not much discussion on the single-pit pour-flush latrines which have been constructed in large numbers in that State. These are said to be working well. The hard clayey soil with low water-table makes a deep unlined-pit viable and it can function for 5-7 years before clearing out is required. The cost at 1980 prices is Rs. 400 with superstructure, and about Rs. 200 or less upto plinth level. (Diagram 6).

Ulta-Matka Privy

An innovation of this design is being tried out at the rural housing complex in Kheda, Gujarat. The novelty of the Ulta-Matka design as presented by the HUDCO delegate, is the use of a large earthen-ware pot buried upside down in a pit and serving as its lining. Maximum leaching takes place

MODIFIED TRADITIONAL WASTE DISPOSAL SYSTEM - AN ILLUSTRATION

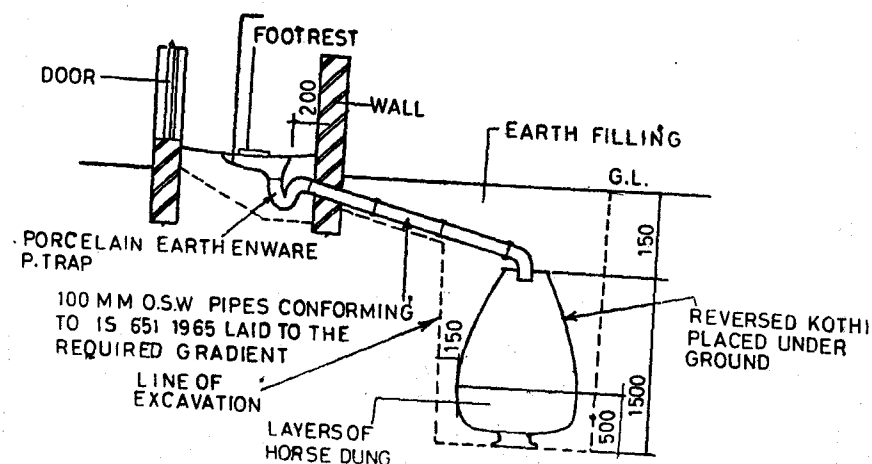

(7)

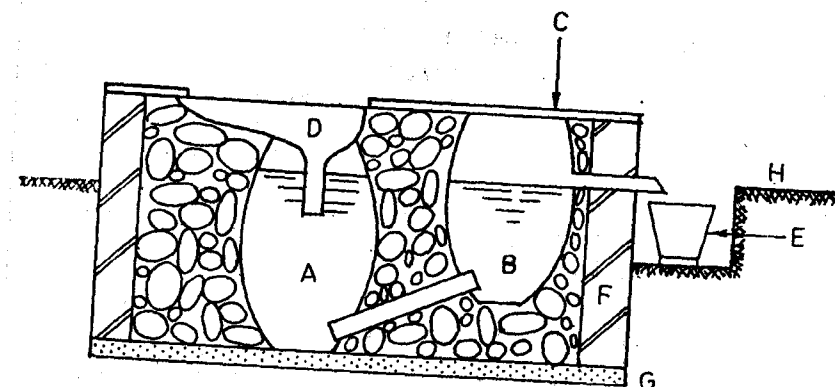

- A. GRIT CHAMBER
- B. SEPTIC CHAMBER
- C. REMOVABLE STONE SLAB
- D. PAN WITH DROP PIPE
- E. BUCKET FOR CARRYING EFFLUENT TO MANURE PIT
- F. 9" BRICK WALL IN MUD MORTAR
- G. 6" TH. LIME CONCRETE
- H. GROUND LEVEL

THE BACHELORS LATRINE

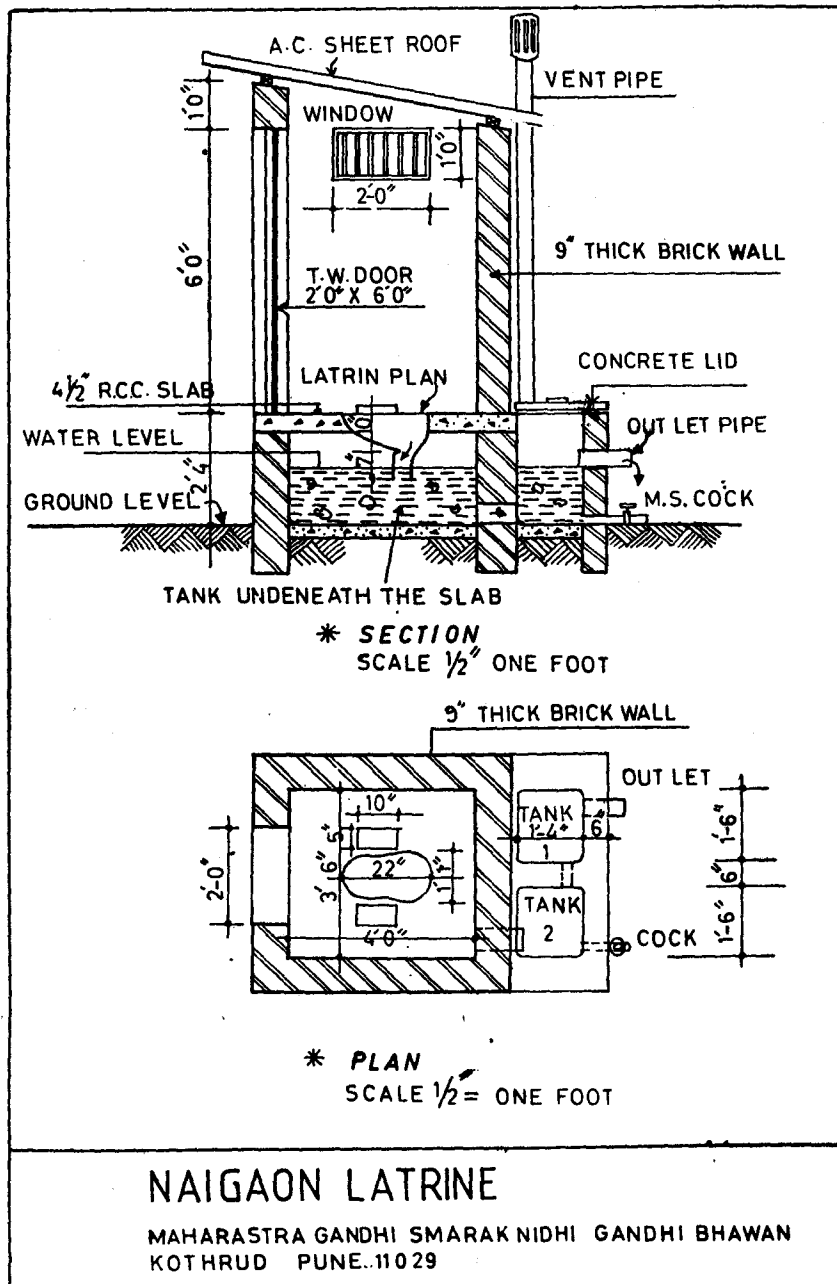

from the open end at the bottom and only a little from the porous sides of the Matka. It should be lined with horse dung in the beginning to accelerate the decomposition process. Users are told to flush with salt water once a week to help liquefaction of the fecal matter, but this was not found advisable by the technical experts at the Workshop. The cost is approximately Rs. 175 upto plinth level (Diagram 7.) It was pointed out that empty bitumen drums with perforated sides can serve as good and cheap pit-liners and are being used in Kerala.

A 'bachelor's latrine' meant for 2-3 persons is on display at Wardha-Centre of Science for villages. Here, two large matkas are used to act on the septic tank principle.

In Maharashtra, the problem is said to be solved through cooperation between neighbours. When a householder's pit is filled up and sealed, he uses the neighbour's latrine and reciprocates the gesture when his neighbour's turn arrives. However, the one-month sealing period before the pit is opened and emptied for re-use is sufficient to destroy all pathogens.

Aqua-Privy

In this type of latrine, anaerobic decomposition takes place in a water-tight tank. The solids settle at the bottom in the form of sludge, while the effluent flows out into a soak-pit; a water seal is maintained by the drop-pipe from the W.C. pan being submerged about 4 inches below the water-level in the tank. This system pre-supposes availability of a certain amount of water. In the Naigaon type aqua-privy constructed by MGSN, the drop-pipe is slightly curved so that fecal matter is not visible from the top. However, it has been pointed out that this can result in clogging of the pipe, thus requiring larger amount of water for flushing.

MGSN has constructed Naigaon-type latrines mostly in municipal areas under conversion of bucket privy programme, for which subsidies are available. Some affluent families in rural areas have also chosen to have aqua-privies. The cost of an aqua privy upto plinth level for 6 users is approximately Rs. 750. Participants were not very much in favour of aqua-privies. It was said that the effluent is usually offensive and risky for health. If steps are taken to eliminate these defects through additional components like soak pits and filters, the cost increases and it no longer remains a low-cost option.

A dwarf-septic tank or modified aqua-privy has been researched and developed at Lucknow by the U.P. Jal Nigam. Efforts were made to cut down costs so that the design became economically feasible for installation

COMPOST PRIVY GOPURI MODEL DOUBLE PIT

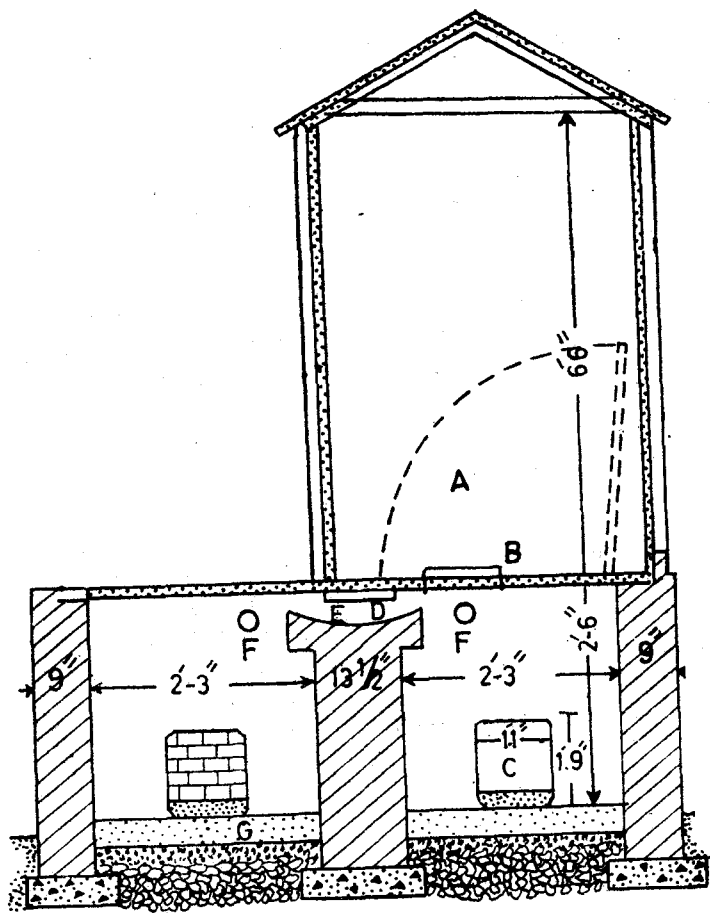

NOTES

- A. TIN OR WOODEN SEAT COVER.
- B. FLOOR COVER AND SEAT OF WOODEN PLANS.
- C. OPENINGS AT THE BACK OF THE PITS FOR REMOVING MANURE.
- D. SLOPING DRAIN BETWEEN UPPER END OF TWO TANKS.
- E. OUTLET PIPE FOR URINE AND WATER.
- F. VENTILATION PIPE IN TANK.
- G. LAYER OF AGRICULTURAL WASTES, ETC. AT BOTTOM OF THE PIT.

in rural areas. It is estimated that the cost upto plinth level in U.P. would be Rs. 750.

The water-tight tank is sited directly under the seat which has a mosaic or ceramic pan with a water-seal trap. Anaerobic action occurs just as in a normal septic tank. The effluent flows out through a pipe into a soakage pit or an upflow filtration chamber. These require to be cleaned after two years and six months respectively. The septic tank is connected by an overflow pipe to an adjoining manure pit. After six months this outlet is opened and the sewage level in the tank drops. The overflow is left to dry in the manure pit and can be retained as rich compost cakes totally free of pathogens.

This design too is feasible only where there is regular supply of water. In the demonstration models, water taps have been provided inside the privy.

Compost Privies

Gopuri and other compost latrines were not paid much attention at the Workshop. Apparently no agency is actively propagating or constructing these at the moment. MGSN tried out a few earlier, but are not building them now. It was stated that fertilizer can be obtained from the matured sludge from leaching pits. But this is available only after long intervals. Compost privies with alternating pits, where the turn-over is quick i.e. six-months to one year, could be an useful and attractive solution for rural areas where fertilizer is of utmost importance.

REPORT OF THE WORKING GROUP ON STATE OF ART OF LATRINES IN REGIONS OF HIGH WATER TABLE

I Definition

High water table regions are defined as areas where pit latrines present problems due to high water level conditions. A practical level of high water table is defined as 1.5 meters and less.

II Problems of High Water Table for Latrines

- 1 Because of rise of water in the pit the night-soil does not flow into the the pit when flushed and water often backs up in the pan. This gives rise to objectionable smell and sight and people refuse to use the latrines.

**DESIGN OF LOW COST SEPTIC TANK
FOR PUBLIC LATRINES FOR POPULATION 150-500**

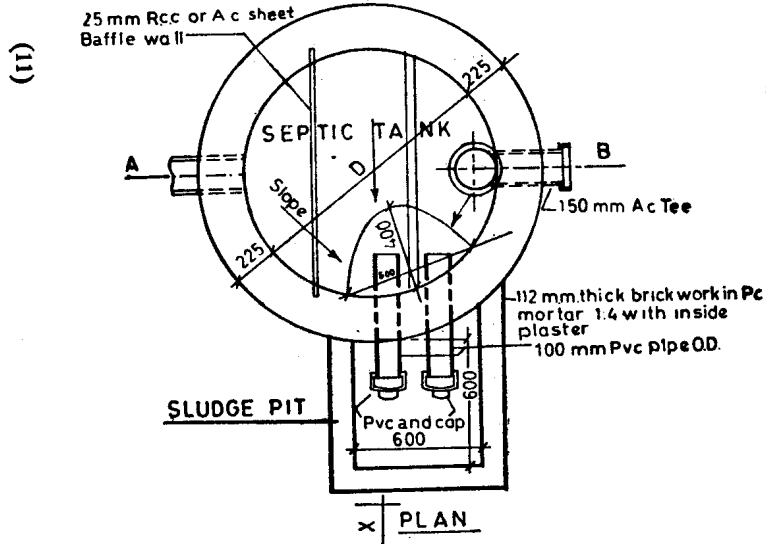
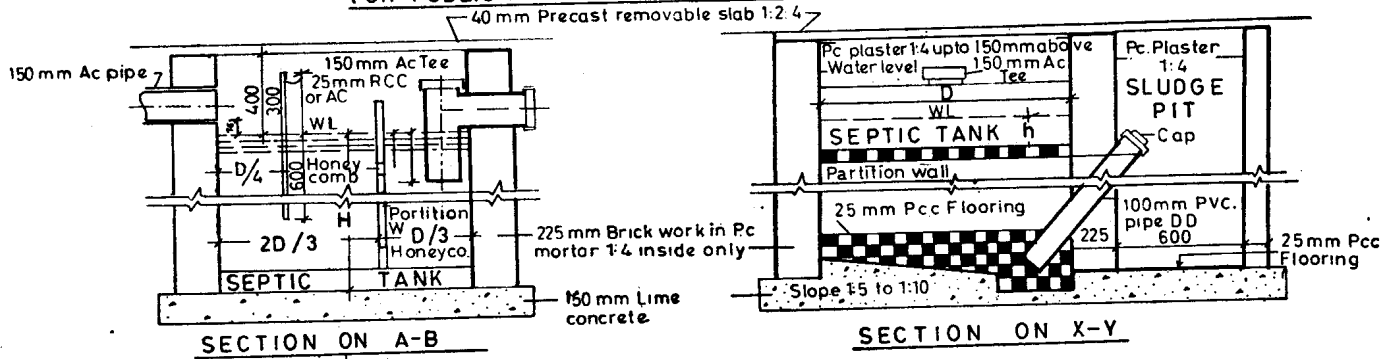

TABLE SHOWING DIMENSIONS OF SEPTIC TANK

Seats	Population	Tank Dia D	Invert level of sludge pipe from liquid level h	Total water depth H	Invert cleaning in a month
12	150	3000	400	1400	3
16	200	3600	450	1500	3
24	300	4200	450	1500	3
32	400	4800	450	1500	3
40	500	5400	450	1500	3

Note:- All dimensions are in m.m.

RURAL SANITATION : TECHNOLOGY OPTIONS

**DETAILS OF IMPROVED DESIGN OF SOAK PIT
FOR POPULATION 10-500**

ALL DIMENSIONS ARE IN MM

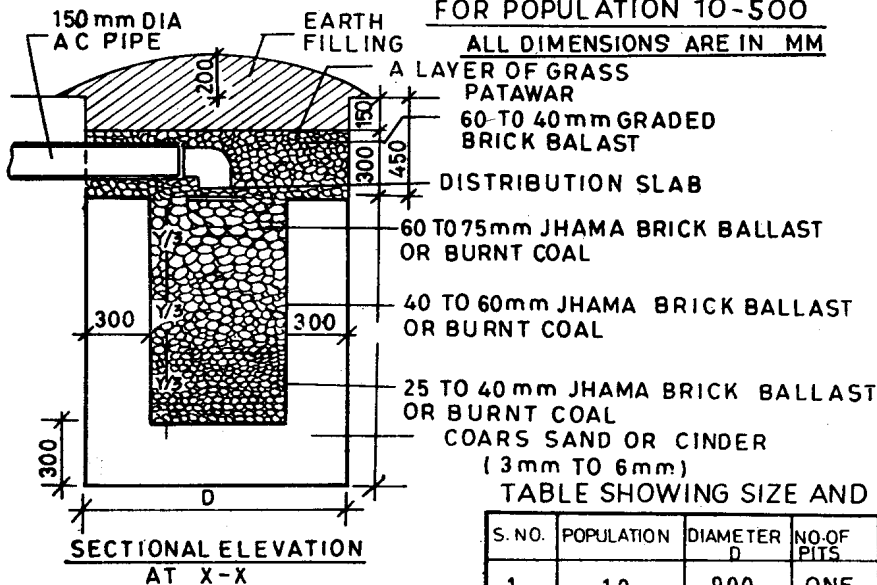

TABLE SHOWING SIZE AND NO. OF SOAK PIT REQUIRED

S. NO.	POPULATION	DIAMETER D	NO. OF PITS	DEPTH BELOW INVERT	Y/3	REMARKS	DISTRIBUTION SLAB
1	10	900	ONE	1200	300	CAPACITY WORKED OUT FOR (DOMAT) SOIL AND SAND MIXTURE	300 X 300
2	20	900	ONE	1200	300		300 X 300
3	50	900	TWO	1500	400		300 X 300
4	100	1500	TWO	1500	400		450 X 450
5	150	2000	TWO	1800	500		500 X 500
6	200	2500	TWO	1800	500		600 X 600
7	300	3000	TWO	2200	630		750 X 750
8	400	3500	TWO	2500	730		900 X 900
9	500	4000	TWO	2500	730		1000 X 1000

NOTE:- FOR PIT DIA. 1500 AND ABOVE, 300mm COARSE SAND OR CINDER LINING SHALL BE PROVIDED AS SHOWN; BELOW THIS SIZE ONLY 150 mm SHALL BE PROVIDED.

SUMMARY OF DISCUSSIONS

- 2 *Pollution*: There is high apprehension of pollution of water table; particularly when there are wells close by. The dimensions of the health hazards, however, have not been quantified. There are no worthwhile studies on the subject.
- 3 *Structure*: There is a danger of collapse of the pit when the water table rises high and the soil is loose. There is considerable evidence in this regard.

III Tried out Solutions

1 *Septic Tank Latrines Followed by Upflow Anaerobic Contact Filters*

This is reported to have been tried out in several regions in West Bengal e.g. Singur and Ganguli Bagan near Calcutta. The final discharge is relatively pathogen free and is relatively clear and odor free. It is discharged into the drain. Obviously the pollution problem is not fully solved. The cost angle has to be looked into.

2 *Modified Septic Tank Developed at CBRI, Roorkee.*

Instead of two, the septic tank has three compartments which increases the retention capacity from 24 hours to 72 hours. It is followed by a down flow aerobic filter which receives bath water also. The septic tank elevation is so fixed that effluent will flow out above ground level. Effluent is reported to be clear and odor free. The pollution potential of the effluent is not fully probed. The cost is about Rs. 1500 (1978 costs).

3 *CBRI—2*

This is being tried to reduce cost of the above to Rs. 450 (1981 cost). Mr. Pathak has suggested further modification. The present model is being tried out in Roorkee.

4. *Sulabh Sauchalaya*

(a) The solution tried is to partly raise the latrine and the pit and make the top part of the pit wall watertight. The lower portion below the ground (say 2 feet below ground level) has a honey comb wall. The wall is surrounded by 1 foot fine sand and the ground below the pit is also filled with 1 foot sand. The sand envelope does not increase the cost and is expected to reduce pollution. However, the pollution potential is yet to be fully examined.

(b) *Sulabh Sauchalaya—2*: This is being tried out for the last 2 months. Here the pit wall is fully water-tight. It is 2 meters high. The level below water table (say 4 feet from GL) is filled with clay soil and the effluent percolates down through the soil.

Conclusion

There is no conclusive evidence of any of the above designs being fully assessed or having been tried out on a large scale.

Mr. Bindeshwar Pathak of Sulabh International will try out all the above ideas more extensively. Other agencies like HUDCO might also do such studies. All members of the Workshop will cooperate and help in monitoring the results.

BIO-GAS FROM NIGHT-SOIL

In the International Decade for Water Supply and Sanitation, a large number of individual as well as community latrines are expected to be constructed to meet the targets set by the government.

Treatment of night-soil is a major consideration for any large scale sanitary programme. The method adopted for safe disposal and treatment of night-soil therefore achieves great importance. One of the methods of sanitary disposal of night-soil is anaerobic treatment in a digester from which the waste matter is recycled in the form of methane gas for various energy needs and the slurry used for fertilizer. The feasibility of adopting such a process depends on a number of factors like technical design of the anaerobic digester, methods of collection (i.e. type of latrine used), dilution, handling of the spent slurry, use of disinfectants for cleaning of latrine and other available alternatives for disposal and treatment of night-soil - like the septic tank or the leaching pit. Availability of finance and social and psychological inhibition in the use of gas generated from night soil for cooking, lighting and other purposes and handling of the spent slurry, are also factors to be taken into consideration.

MGSN Plant

Discussion of bio-gas plants started with digesters attached to individual latrines. MGSN has been constructing digesters with their 'Sopa' type latrines. This model has been recognised and accepted by KVIC in 1981. More than 100 such gas plants have been constructed. The Plant consists of a digester with a water jacket, steel gas holder, an inlet which is attached directly to the latrine pan by a pipe laid to a steep gradient and an outlet from which

LATRINE GAS PLANT

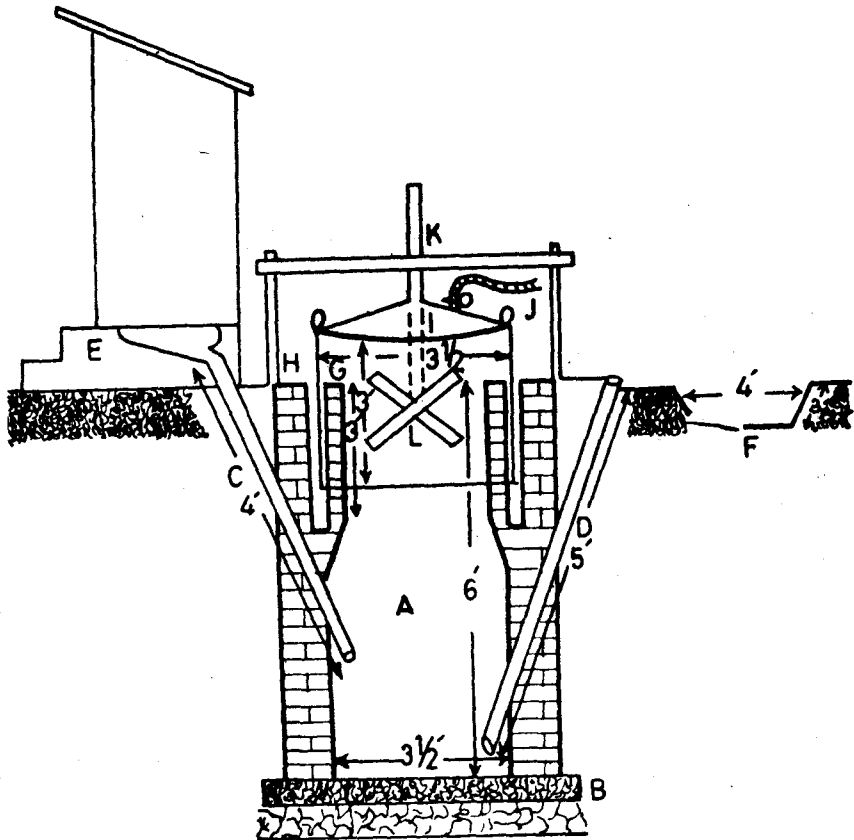

—MGSN Design

(13)

LATRINE CUM GAS PLANT

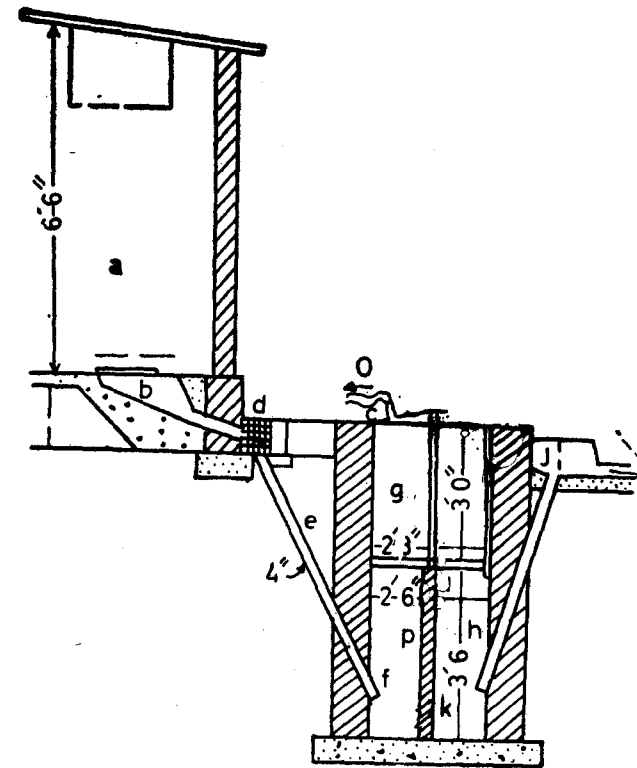

—KVIC (Gujrat)

(14)

the slurry is drawn out. The pan is so designed that small amounts of water is sufficient to flush the night-soil thereby ensuring proper dilution. One of the main factors mentioned was that the plant and the latrine should be close to each other, because otherwise, considerable difficulty is encountered in the passing of night-soil from the pan to the plant and excessive amounts of water may be needed to flush the latrine. The top of the digester wall should not be much higher than the ground levels otherwise the plinth level of the latrine will also have to be raised leading to additional expenditure.

One of the surprising features about the design is that the digester has no partition wall in the plants which use only night soil. However, if gobar is used to supplement night-soil, a partition wall has to be constructed. There is also a provision for a rod with blades attached to one end, which can be used to break the scum layer of the slurry.

The danger of the slurry from night-soil based plants containing active pathogens is eliminated in the MGSN system. The liquid slurry does not have an offensive odor nor does it attract flies. The slurry is left to dry in drying beds before being packed and sold in dry powdery form.

For increased benefit, individual gas plant owners allow use of their latrines to outsiders, specially women from neighbouring families. A single household plant can serve lighting and partial cooking needs of a family of 6 or 7 members.

MGSN has a plant working at Gandhi Bhavan, Pune. It is attached to a latrine used by 14-16 persons every day and on an average, 19-22 cub. ft. of gas is obtained daily. The gas is used to burn a hearth of 4" dia for about 90 minutes.

MGSN has constructed other community night-soil based plants. The first plant is at Raju Sathya Niketan, Ahmednagar district. The second in Pune district and the third at Amravati District. The advantages of MGSN type of plants is that the night soil is transferred directly into the digester. Scavengers' services are dispensed with - in keeping with the aim of the Bhangi Mukti Programme. Another advantage of these plants is that septic tanks which are 5 to 6 ft deep and under the ground, can with minor changes, be converted into such gas plants. These plants can however be used where only a small quantity of water is required for flushing and a large number of people use the latrine. One disadvantage encountered is that the metal flap used in the pipe from the tank to the plant corrodes and has to be changed. The metal gas holder is also subject to corrosion and needs changing, adding

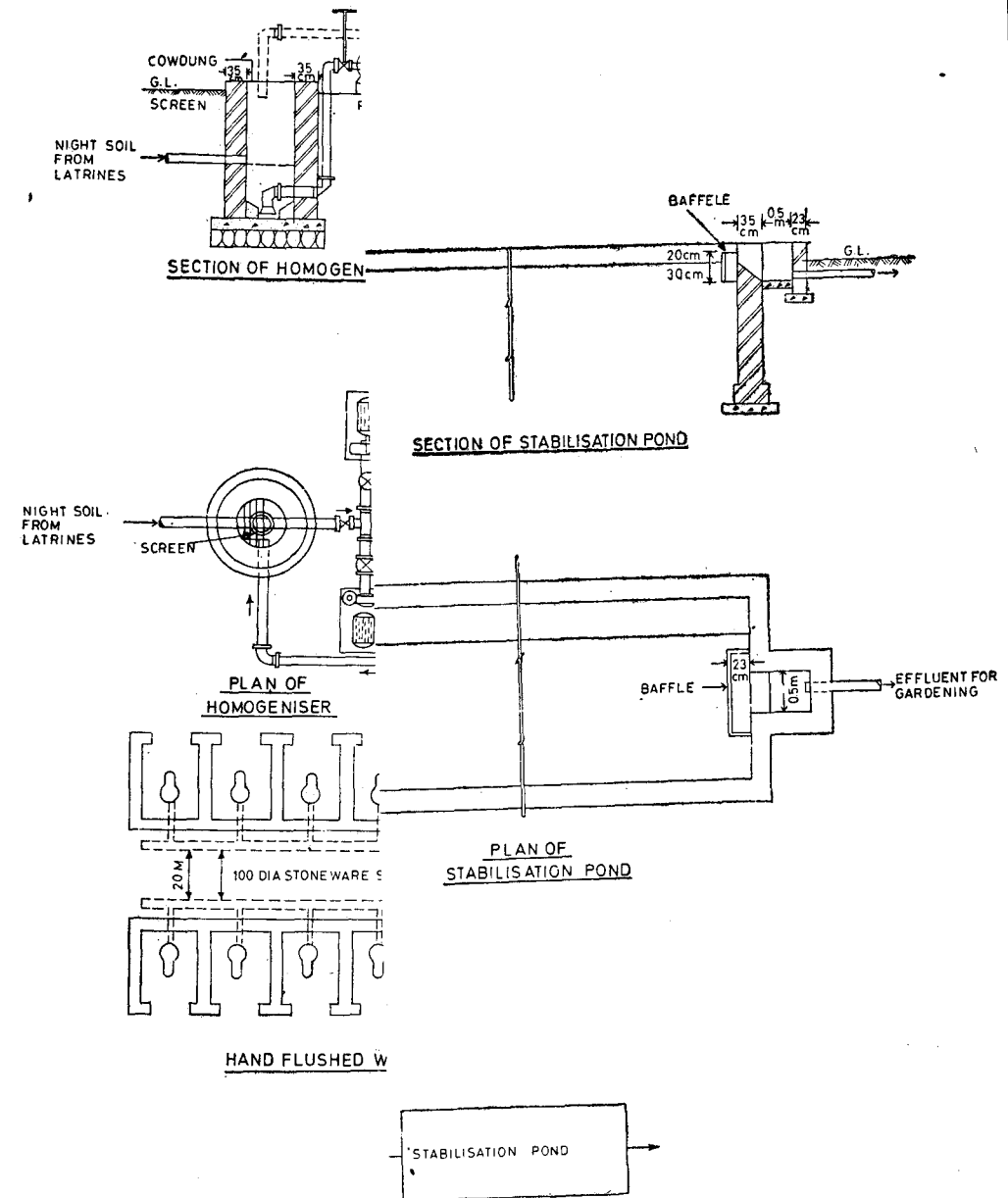

57

MODIFIED SAMPLE SCHEME OF NIGHT SOIL DIGESTION

AS PER DECISIONS IN P.M.6 MEETING ON 20.7.1977

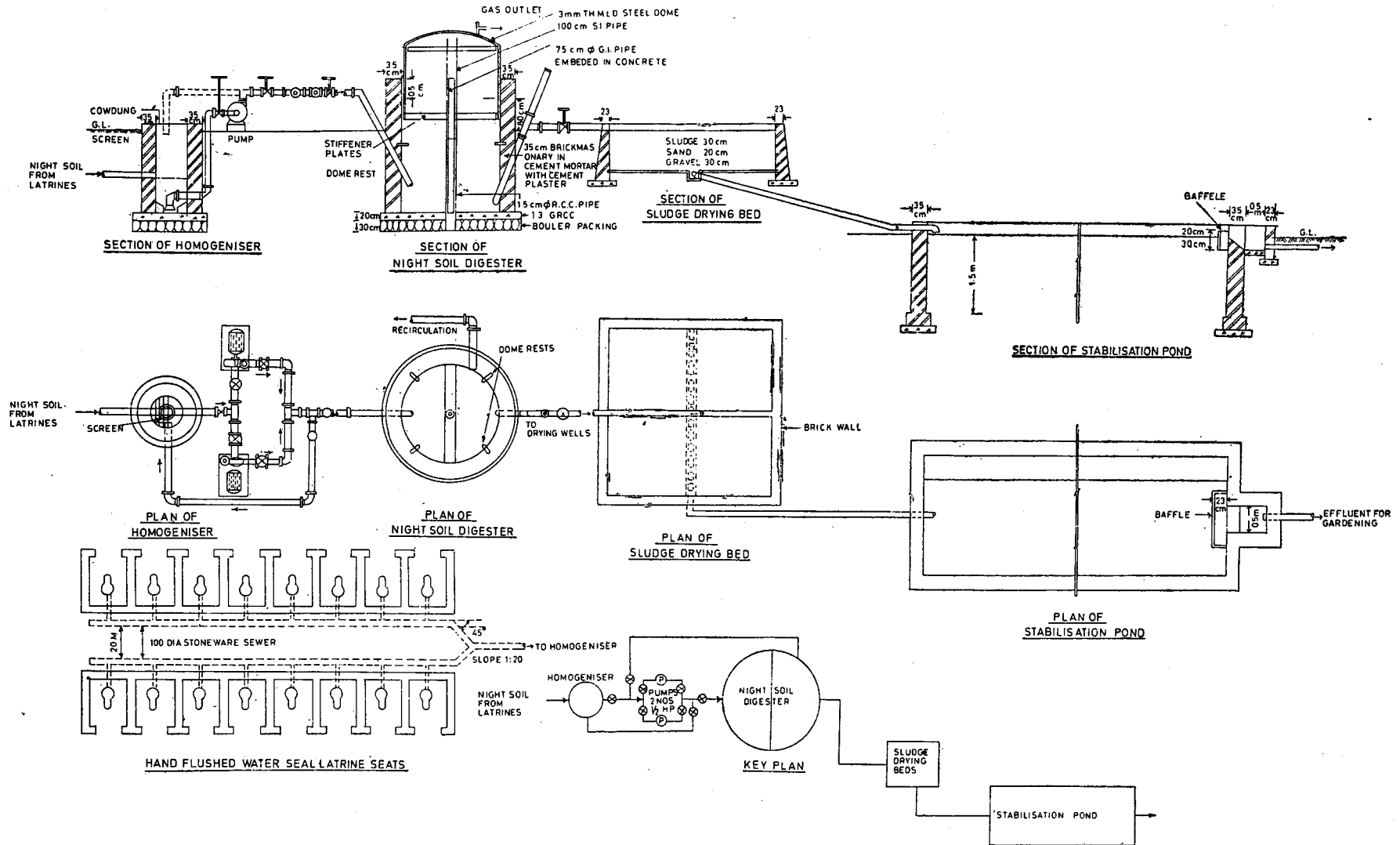

to maintenance expenses. MGSN is trying out fibre glass gas holders in community gas plants to overcome the problems of corrosion.

NEERI Plant

A night-soil based gas plant has been designed and constructed by NEERI at the Nagpur central jail. The plant is situated behind the jail and is fed by scavengers who transport the night-soil from the dry latrines to the plant. The gas obtained is used for cooking in the jail's kitchen. The slurry obtained is treated in the following stages:

The slurry is passed over a filter, which is a sand drying bed. The water from the slurry percolates down through the sand and collects below. The solid particulates of the slurry forms a cake on top of the bed and can be manually removed and used as fertilizer in the fields. The water which has percolated down contains small amounts of organic matter and is further treated in an oxidation pond. After being treated in the oxidation pond the water can be used for irrigation.

The NEERI plant is not using any other materials to supplement the night soil for loading the plant everyday.

The major draw back with the NEERI plant is that it depends on the dry conservancy system which is inimical to the concept of Bhangi Mukti.

AFPRO Plant

AFPRO has constructed a 15 cu. mtr. night-soil based pilot plant in Midnapur, West Bengal. The plant is fed by the scavenger community of the city, who used to transport the night-soil in wheel barrows to the city dump. Now they dump a part of the nightsoil in the inlet of the plant. A mechanical stirring device is provided at the inlet to mix the slurry.

The plant is designed on the Janta Model, developed by PRAD. The gas is used by 7 families, who have a piped supply of gas for 24 hrs and they use it for cooking and lighting. A burner and a lamp have been provided by AFPRO for this purpose. The total cost of the plant, pipes and accessories is about Rs. 17,000 and has been borne by AFPRO. The feeding and maintenance of the plant is the responsibility of the beneficiaries, which consist of the 7 families who presently use the gas.

It is however understood that the plant will soon be handed over to the Midnapur Municipal Corporation after it has been proved that the plant is functioning. AFPRO does not anticipate any problems in the functioning.

of the plant. The outgoing slurry will be taken to the pit by the drain, dried and then used as fertilizer or disposed in any other suitable manner.

AFPRO plans to construct one other plant based on night soil at the Mynoor village in Trichur district of Kerala. The plant will have a capacity of 10 cu. mtr. of gas and will be fed directly by a community latrine used by 30 to 40 families. The design will be that of a Janta bio-gas plant. The gas from this plant will be used for lighting and running pumps, but not for cooking. Fuel for cooking needs will be supplied by another plant constructed by AFPRO having a capacity of 15 cubic mtr. and fed with only gobar.

The AFPRO plant at Midnapore has one obvious disadvantage. It has to be manually fed by scavengers who collect night-soil from the place of generation.

However, the AFPRO plant at Midnapore has one big advantage over the MGSN plant. It does not have a movable steel gas holder and the maintenance costs are much less. Besides the cost of constructing a Janta plant is also lower than a KVIC type plant.

AFPRO is keen on providing technical services for Municipal Corporations and other voluntary agencies interested in constructing gas plants using night soil.

Gorakhpur Plant

The Indians railways have constructed two bio-gas plants of 6 cu. mtr. each near the Gorakhpur station. The plant is fed directly from the two rows of 10-12 toilets constructed on the platform. The gas from the plant is used by the railway's canteen kitchen. Details about the design adopted and how to regulate the water content in the slurry were not available at the Workshop. (See diagram from the print made available later)

A contractor is responsible for the maintenance of the plant. He earns approximately Rs. 800 per month from the gas sold to the railway canteen.

The slurry generated by this plant is presently disposed of in the city sewage system.

The Gorakhpur plant may offer a concrete solution for the safe disposal of night soil. The plant is fed directly from the toilets, hence no scavengers are required to feed the plant or mix the slurry. However, a few questions like water content of the slurry, design of the plant, toilet pans used and

FOR
SEE I

maintenance costs have to be answered before such a plant can be considered for implementation on a large scale.

Other Efforts

Mr. Ibrahim of PRAD has constructed a 350 cu. ft. plant at his residence in Lucknow. The Plant is designed like a Janta plant except for one difference—it has 3 inlets. One inlet is for the night-soil coming in from the house, the second inlet is for the scavengers and the third one is for cow dung. Since the quantity of nightsoil available from the household latrine is not large enough for such a plant, about 100 kgs. is fed to the plant every day by the the scavengers. In case the need arises, gobar can also be used to feed the plant through the third inlet.

The outgoing effluent from the plant goes to a soak pit. Presently the slurry is not being utilised for any purpose. The gas generated is used for cooking and lighting.

Mr. Ibrahim has constructed 5 such plants in Lucknow. The disadvantage of this plant is that it has to be fed by scavengers and the effluent generated is not being used at all. However, the plant is based on the Janta design and does not require expensive maintenance. The cost of the plant is about Rs. 3500 only.

Blue-Prints for Gas Plants Attached to Community Latrines

A number of agencies have prepared blue-prints for the construction of night-soil based bio-gas plants directly attached to community latrines.

Chief among them are (1) NEERI, (2) MGSN, (3) U.P. Jal Nigam, (4) HUDCO, (5) CBRI. These organisations are prepared to collaborate with any implementing agency which is interested in constructing any of these models as pilot plants—for trying them out in the field. The designs and (s) schemes are presented in Annexure 6. Tamilnadu Housing Board has also developed a concept of radial design for housing linked with a bio-gas plant based on right soil. A Rural Housing Project of 192 houses has been taken up at Guddalore, Chingleput district.

**LAY OUT DRAWING OF NIGHT SOIL GAS PLANTS
CONNECTED TO COMMUNITY LATRINES
SPACE REQUIREMENT 8m X 9m**

SCALE :- 2cm=1m

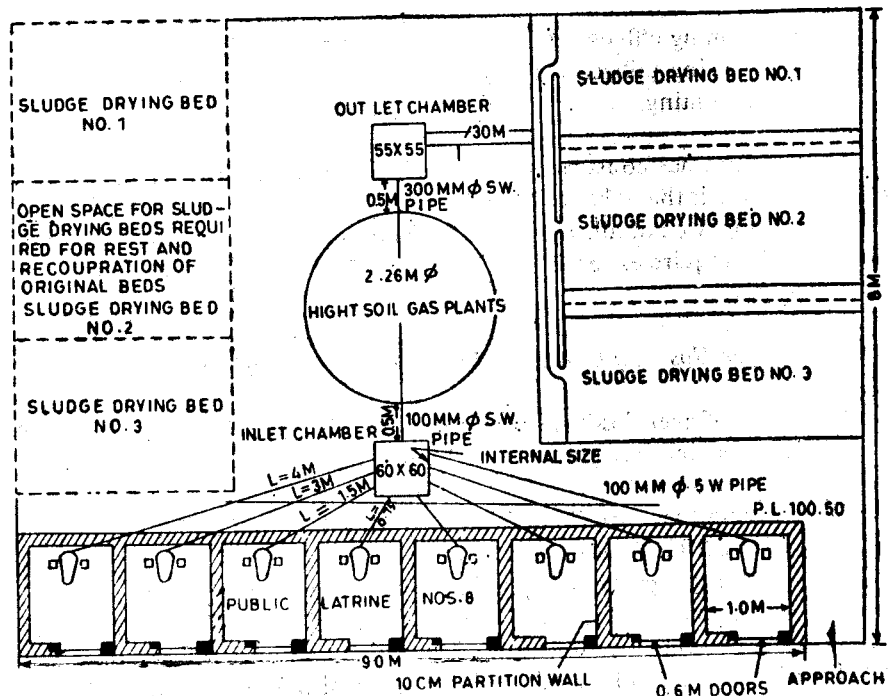

(17)

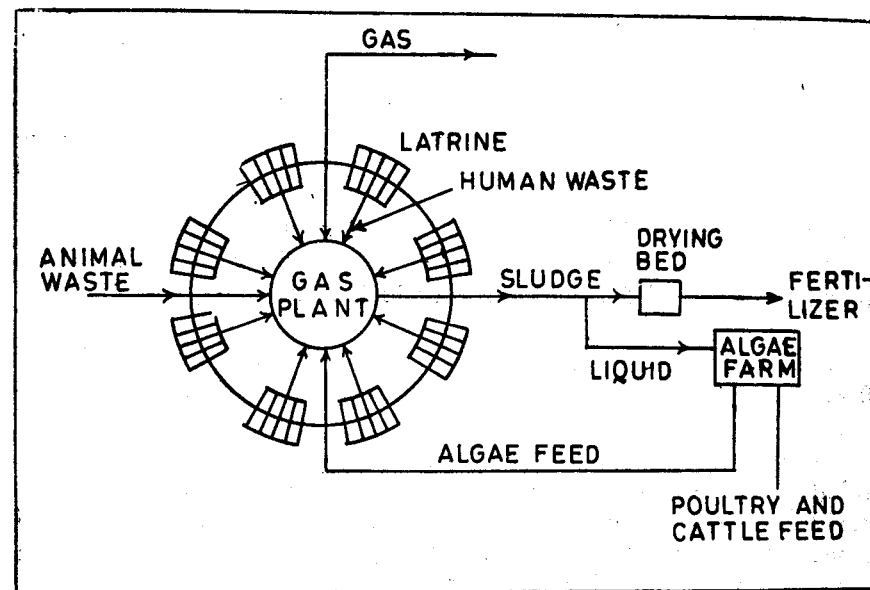

WASTE PRODUCT GAS PLANT AN INTEGRAL SYSTEM

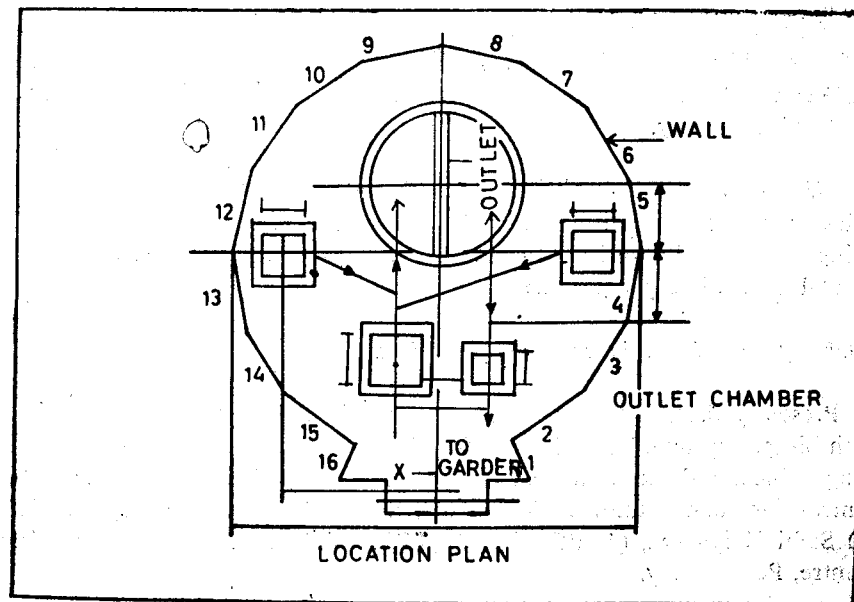

LOCATION PLAN

(18)

REPORT OF THE TECHNICAL PANEL ON NIGHT-SOIL
BASED GAS PLANTS

For individual families a night-soil based plant will require excreta from about 60 persons to meet the cooking and lighting fuel requirements of one family. (Average of 5 members for a middle class family)

2 For an individual family night-soil along with animal dung of about 30-40 kgs would be sufficient to meet the requirements of one family.

3 Technology of production of bio-gas in situations mentioned above is available. However, when night-soil is used in the digester there is a need to provide a minimum retention time of 12 weeks before the slurry is removed for use. This will meet the public health objections, if any. The retention time of 12 weeks may include a period of anaerobic decomposition in the bio-gas plant and period of decomposition in attached compost pits.

4 Since majority of the families do not have enough cattle, it is essential to find out if kitchen refuse or any other household refuse or agricultural waste can be used as supplement for providing enough gas for the requirements of the family.

5 Wherever feasible, attempts should be made to integrate different activities such as construction of latrines, bio-gas, compost pits etc. which are being promoted by various agencies in villages as a part of rural environmental sanitation programme.

Lack of experience in community latrines

Presently there is not enough experience in linking community latrines with bio-gas system. There is need to take up some pilot studies in different geographical and climatological areas in the country. It is suggested that the centres for such studies could be: (1), Sulabh International, (2) NEERI, (3) Safai Vidyalaya, (4) PRAD, (5) MGSN and (6) Orientation Training Centre, Poonamally.

Pilot studies should take into consideration the health aspects and also space constraints for the disposal of the effluents from the plant. In order to consolidate the experiences available in the above subjects a team of 4-5

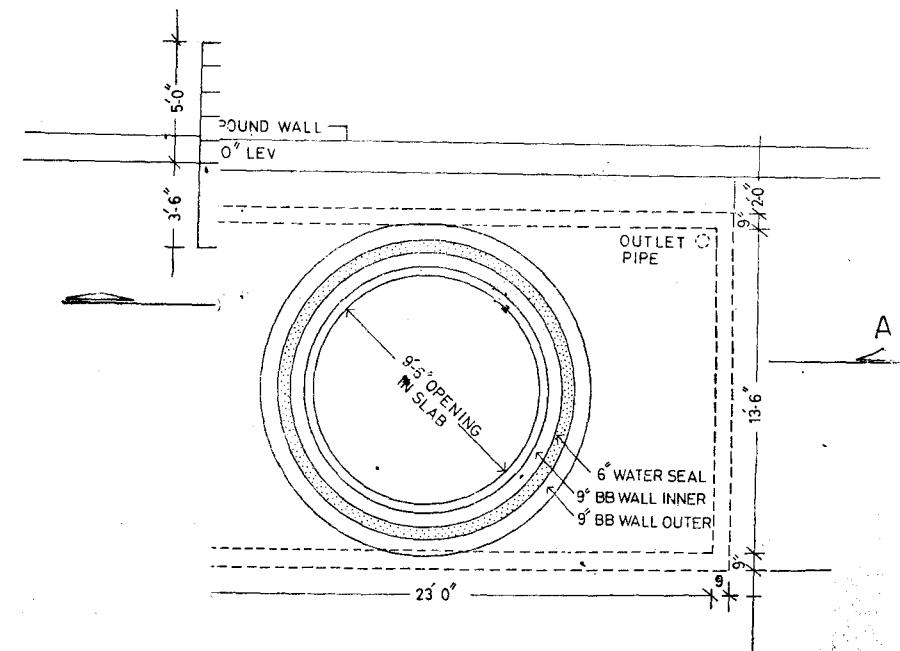
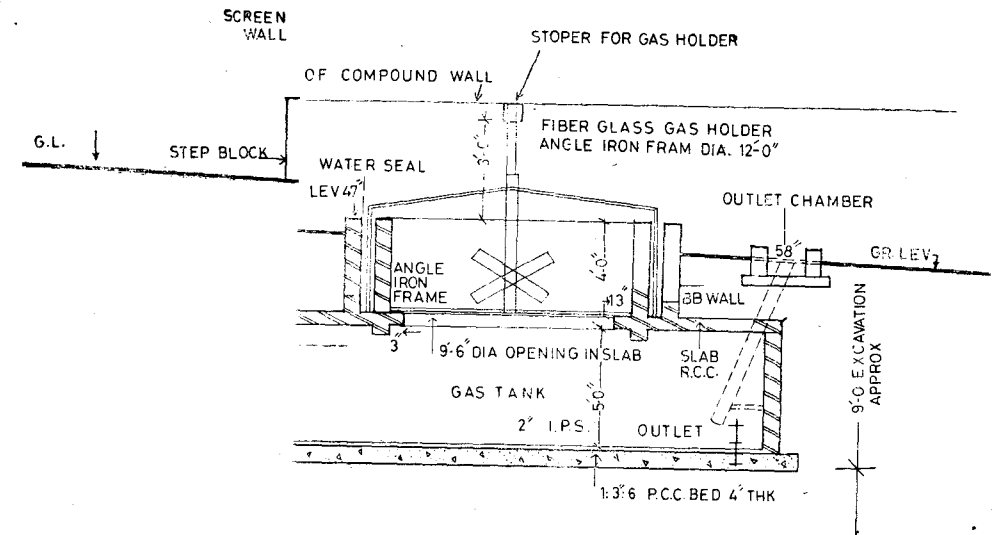

EN WASTE

IRDI, PUNE 411035

persons may visit the places listed below to prepare a report indicating all aspects of transfer of the technology.

There is a need for establishing statewide committed and competent organisations for the implementation of the programme.

Names and places to be visited:

- | | |
|-------------------------------|-------------------------------|
| 1 NEERI, (Nagpur) Maharashtra | 7 Okhla (Delhi) |
| 2 MGSN (Poona,) Maharashtra | 8 Khoraj (Gujarat) |
| 3 Gorakpur (U.P.) | 9 Gandhi Nagar (Gujarat) |
| 4 Lucknow (U.P.) | 10 IIM (Ahmedabad) |
| 5 Quilon (Kerala) | 11 Gudalore, Chingleput, T.N. |
| 6 Trichur (Kerala) | |

CHULAH

The importance and need of developing and popularising a smokeless fuel-efficient, time-saving domestic chulah for considerations of health as well as energy was readily accepted.

Three types of improved chulahs were discussed. The design used by MGSN and Safai Vidyalaya, Gujarat, is being used also by Thapar Polytechnic, Patiala. This is a modified version of the HERL chulah developed in the fifties. It can be made of clay and brick and consists of a 2-hole chulah with a chimney. A baffle wall is placed between the holes (See diagram). A shallow excavation in front of the fire-hole or a brick laid flat, serves as a space or platform to bake chapatis and also to support longer firewood sticks. According to the T.P. representative, a grill of M.S. rods in the fire-hole is of great importance, since it helps in combustion and also separates ashes which can then easily be cleaned out. The chimney pipe of 4" dia can be made of different materials but it is essential to clean it regularly. A milk boiler can be attached to the end of the chulah so that the chimney draws away the smoke. A damper is provided between the 1st and 2nd hole for regulating the heat or if only one hole is to be used.

The chulah has been well accepted in Punjab villages where TP has been working. Women appreciate its advantages. One village has been saturated by 100 chulahs.

About 200 bricks are required for a standing chulah and 80 for a 'sitting' chulah. Usually these are available on site in Punjab households. The cost is Rs. 15-18. A trained mason can make 4-5 chulahs a day and would cost Rs. 5-6 per chulah. So far the mason's services are provided free by the

GUJRAT CHULAH

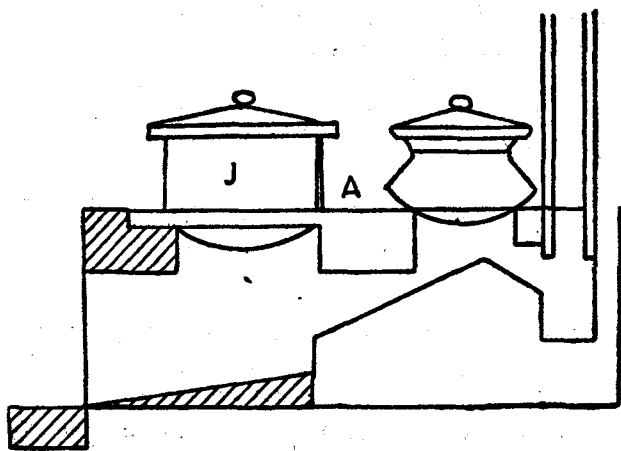
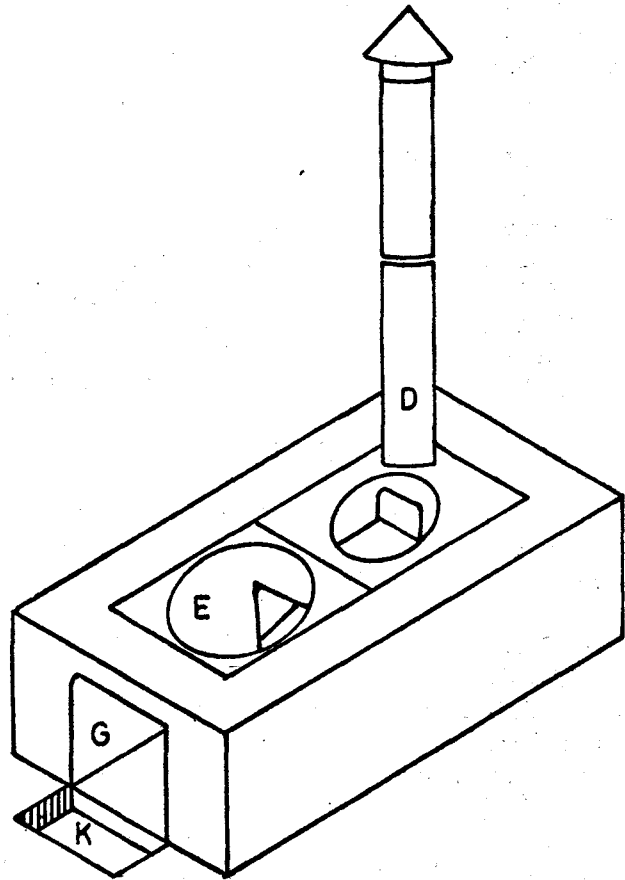

SMOKLESS CHULLA

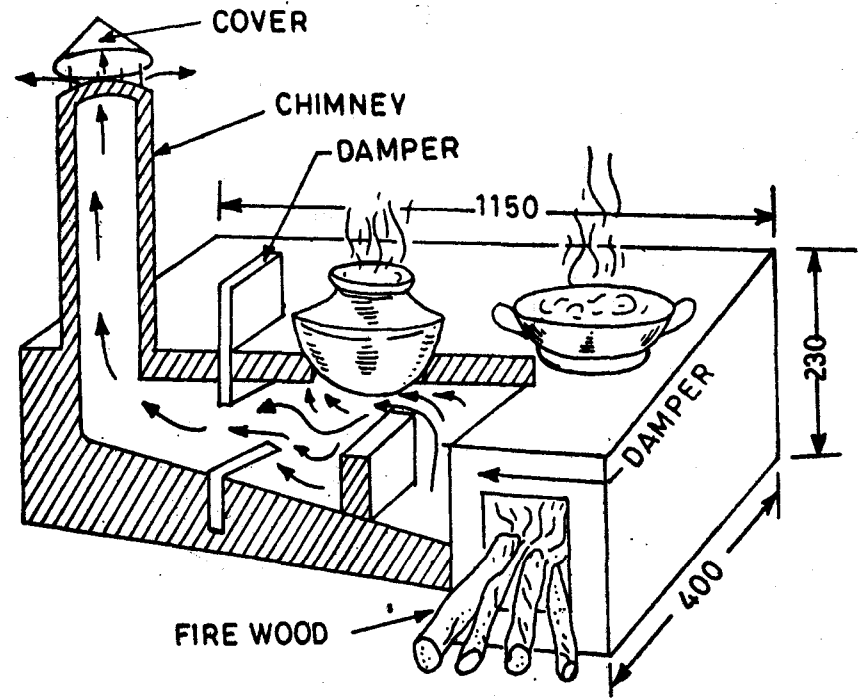

ALL DIMENSIONS IN MM

(21)

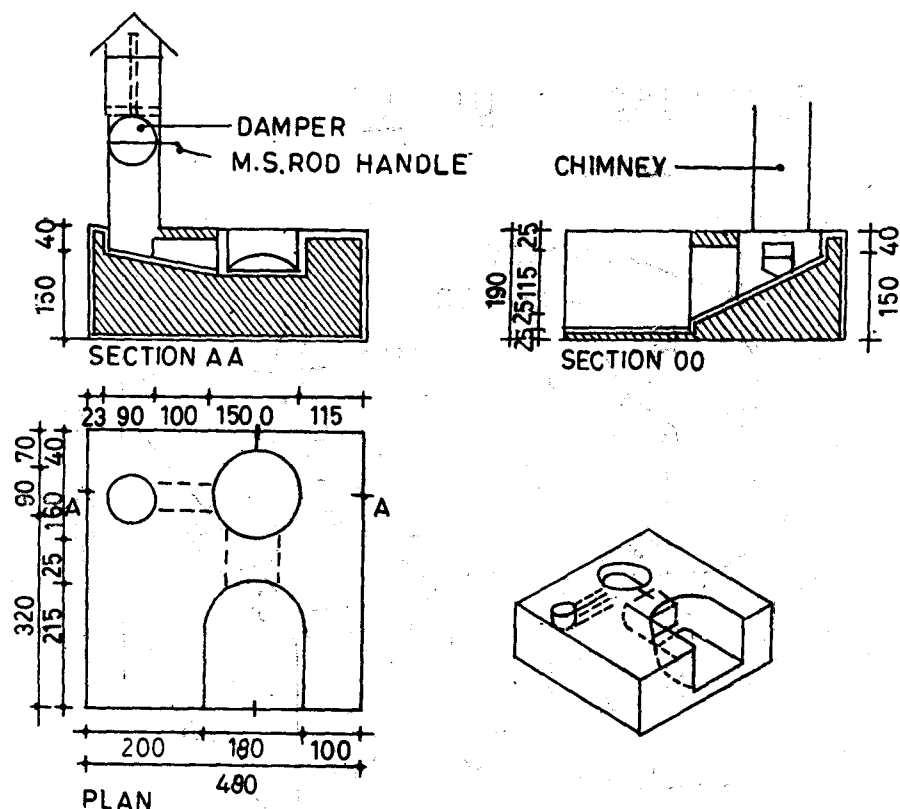

IMPROVED TYPE
SMOKELESS CHULLAH

N.B.O.

(22)

extension agency. It was felt that beneficiaries should be asked to pay Rs. 2—3 only.

In Maharashtra, the soil is not always suitable for making chulahs. Special type of mud has to be obtained. Women who specialise in making chulahs are trained by MGSN and they make them for others. Local tin-smiths sometimes make the chimneys out of used tin. In some cases reed pipes are woven into mats and covered inside and outside with mud. A grating is found useful as ash collects underneath and can easily be cleaned out.

No grant or subsidy is available for this purpose.

The NBO model, developed by PRAD, was displayed. It was explained that this model was chosen as the most effective in terms of fuel economy, and time saved, from a study of 50 odd models in use all over the country. This is also a two-hole chullah with a chimney, but the first hole is amalgamated with the fire-hole very much like a traditional chullah. This model is made of a clay and bhoosa mixture; if it were slightly smaller and lighter, it could make a good portable model. This design is being propagated by the NBO which has provided them in their demonstration housing clusters. Some doubts were voiced regarding smoke elimination since the first-hole is open-ended. This has been done to enable villagers to bake chappatis in the traditional manner. It was stated that 95 per cent smoke goes out through the chimney. (Details with diagram). There is provision for a damper in the chimney to regulate the heat. It was found that 1 kg firewood is required for the daily cooking needs of a family of five.

The third design discussed is the type being constructed under a Ford Foundation scheme in some villages near Chandigarh by Ms. Madhu Sarin. This design is based on the Lorena stove developed in Guatemala. Also made of clay and bhoosa mixture, this can be a 2-hole or 3-hole chullah. Here the emphasis was on creating indirect and narrow flues so that the heat was made to take a circuitous route before passing out of the chimney as smoke (Diagram). Small mounds are built beneath the cooking holes to force heat to squeeze past. A grill was felt to be unnecessary in this model, but two dampers are provided, one between the firehole and the first cooking-hole and the second in front of the chimney hole. These are used to regulate the draft and therefore the heat in the stove/chullah. Both can be manipulated from outside. The chullah is structured with 'gara' (mud and bhoosa) cakes, prepared and sun-dried in advance. After the frame and the flues have been made, the remaining hollow places are filled with loose sand and the top covered with 'gara' cakes. The pot-holes can be varied to suit pot sizes in individual homes. A mould for this chullah was suggested but did not find favour with Ms.

SMOKELESS CHULAH ADAPTED FROM LORENA STOVE
 (BEING CONSTRUCTED UNDER A FORD FOUNDATION SCHEME
 IN VILLAGES AROUND CHANDIGARH)

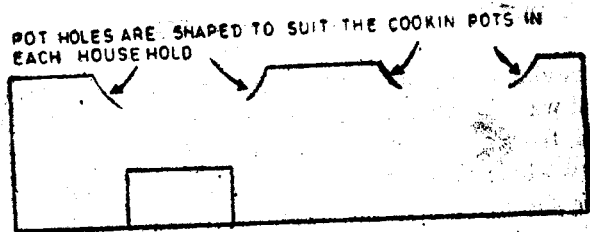

THE OUTER SURFACES AND THE FLUES AND BAFFLE IN ALL ARE MADE OF 'GARA' - MUD AND BHOOSA MIXTURE DRIED INTO SHEETS IN THE SUN AND THEN USED ACCORDING TO SHAPE REQUIRED

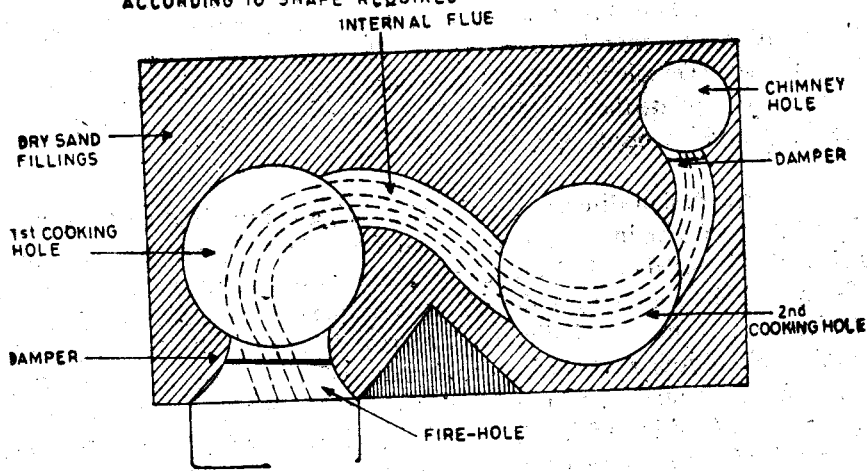

(23)

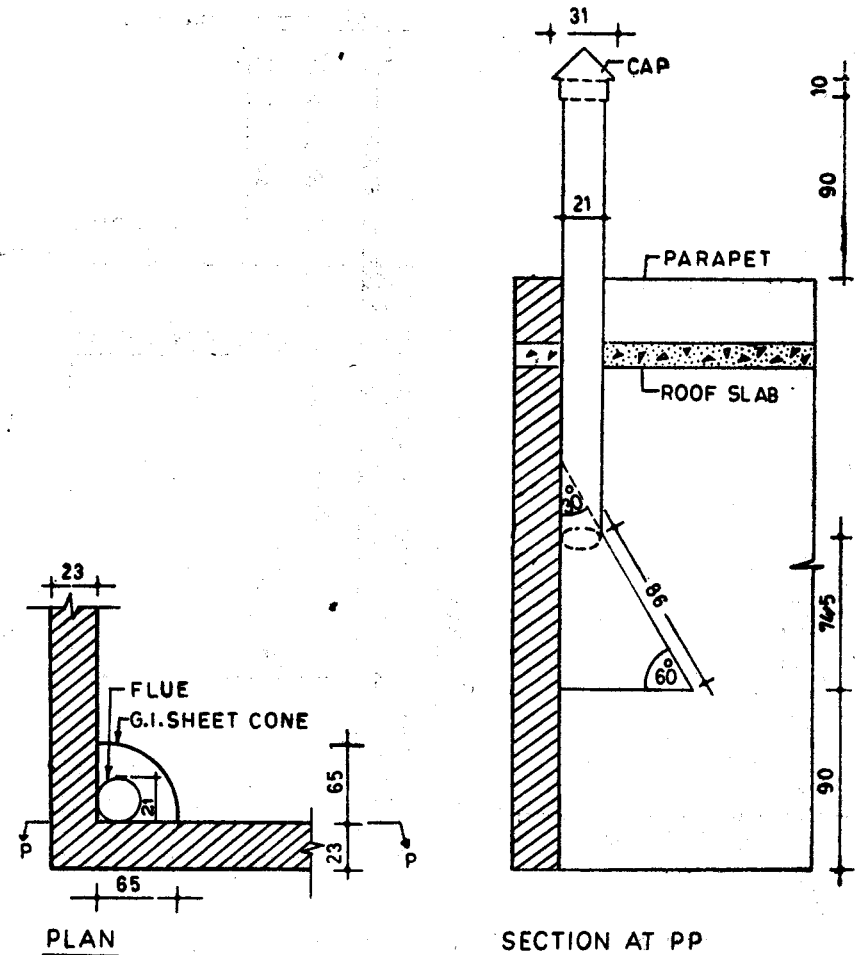

(All the dimensions are in cms.)

SKETCH OF G.I. SHEET CHIMNEY

(24)

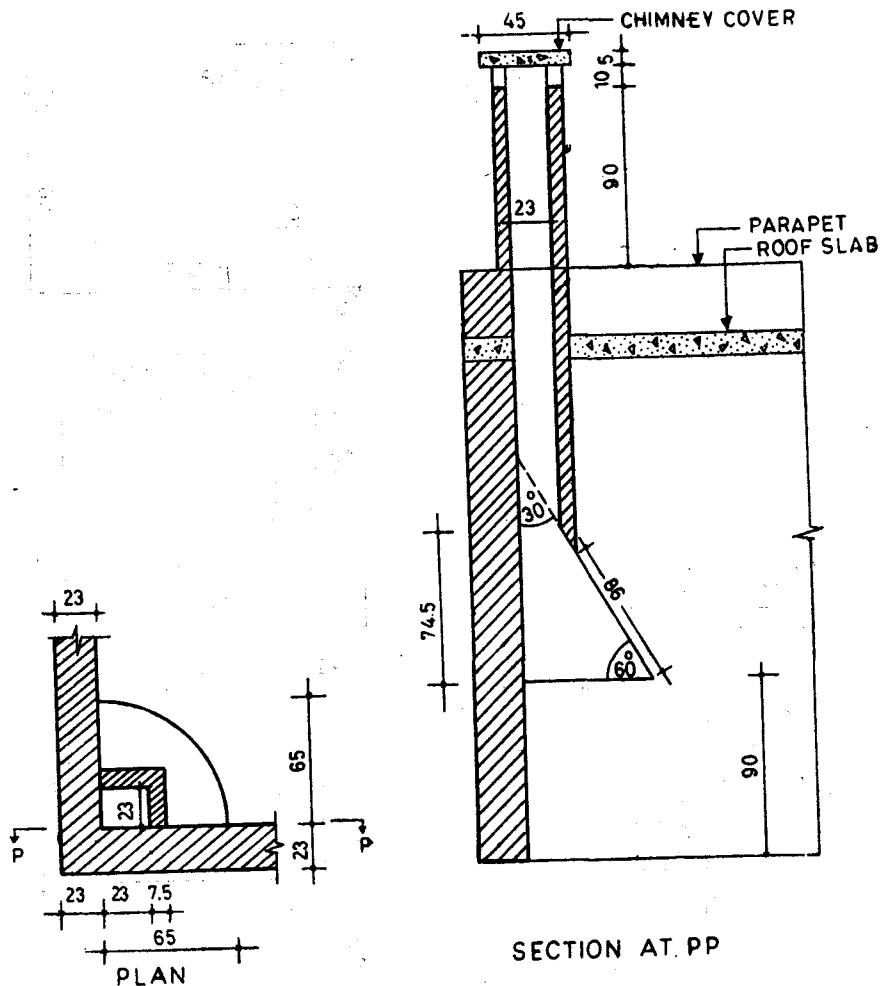

(All the dimension are in cms)

SKETCH OF MASONRY CHIMNEY

(25)

Sarin, who feels the flexibility regarding exact design is to a great extent responsible for its popularity.

It was explained that locating the chulah in the right spot/corner of the room also contributes to convenience, efficiency and therefore greater use of the chulah. She also felt that her informal, gradual approach, though slower, was more effective in introducing a modified technology into the rural areas. (Diagram)

Women who have watched Ms. Sarin have now started making their own chulahs.

It was observed that the technology for smokeless chulah is simple enough, but the dimensions of cooking holes, chimney, damper etc. can and do make a difference to efficiency and therefore should be constructed carefully and according to specifications of the design. Users should be carefully taught how to use the chulahs and manage the dampers to regulate flow of air and control heat.

Mr. Ibrahim of PRAD displayed diagrams of the ovens he had seen in China. These are usually 3-hole chulahs with a fire-hole in front of each cooking hole which are joined by a flue to convey the smoke through the chimney. The chimney is of masonry and built into the building. He explained that he had seen the same chulahs being used with firewood, coal and bio-gas according to the availability of the fuel. It was recommended that he build a prototype and try it out.

Although the cost of these chulahs is low, it may be out of reach for the poorer villages. At any rate, initially, it would be well-worth while to subsidize part of the cost, if not the whole. It was pointed out that the chulah is such an integral part of the family life, specially the women's, that it is an ideal choice for obtaining a break through in introduction of technology into the lives of rural people.

Items like MS rods and material for the chimney pipe are not easily available at village sites and should therefore be provided/carried by the extension agencies.

A chimney for the kitchen corner has been designed at CBRI by Dr. Ishwar Chand. This is not attached to the chulah but located above it. It is quite effective nonetheless in drawing away smoke from the chulah, (Diagram: Annexure 8). The chimney consists of 21 cms diametre pipes which should rise 2 metres above the roof. A clear gap is left between the pipe and the hood of the chimney. The cover prevents entry of rain water and also back draught.

METHODOLOGY OF EXTENSION : SOME VIEW POINTS AND EXAMPLES

Having reviewed the technology available for the three items under consideration, attention was turned to the methodology of extension. Discussions centred on the (1) social process of introducing new ideas and technologies among rural people, (2) the required policy support, (3) budget, and (4) organisational support.

Savitri Behn of MGSN pointed out that the best way to approach people is in their own villages, in their own atmosphere. Camps, for demonstration and training, of varying duration, are held in the villages. After an interval a follow-up visit is made to monitor the progress.

Training courses of one-month duration are held by MGSN at Pune. The trained people are sent to the villages for extension work. Some times they are paid a salary and sometimes on piece-basis.

Bhajans, Kirtans extolling the virtues of the programme, are held, to persuade the people. When a pujari takes food cooked with gas from a night-soil based plant, or offered by a Harijan, the example is hundred times more effective than any number of lectures.

People must have faith and confidence in the extension organisation, who must work hard and patiently, to achieve this. Social education is a slow and long process in which voluntary agencies have a vital role to play. Once the idea catches on, individuals do come forward, but only an organised agency with the necessary infrastructure can provide the impetus to carry through the programme.

The well-to-do land owning families were the first to install sanitary latrines in their homes. They were followed by service people who wanted the facility specially for the women folks. The artisans and the labourers were the last to adopt the new system and habits.

MGSN has started its programme (basically with the objective of Bhangi Mukti) since the fifties. Till 1973, there was no financial support from the Government; 90 per cent of the funds were met by MGSN itself.

Now there is no direct financial help but the programme is backed by the local government bodies—at the block and panchayat level. In 1974, Rs. 25,000 was sanctioned for the programme of rural sanitation, by the Maharashtra government. The amount has been increased over the years—Rs. 1 lakh was given in 1979-80.

The Maharashtra government is dependent on MGSN which has built up a solid base among the people, to carry through some of its programmes under IRDP. Rs. 6.5 lakhs have been sanctioned for the purpose and routed through MGSN, which supervises the implementation and provides the certificates.

Under SFDA, those with less than 3 acres are given subsidy for the manure programme to which latrine construction is tied up.

Government sanitary inspectors and overseers are sent for training to MGSN. Village camps are sometimes organised with the help of government bodies. Expenses for government personnel is borne by the government, others are usually trained free by MGSN.

It seems in Maharashtra now there is a happy interaction between the government authorities, the voluntary agency (MGSN) and the people, with the second acting as the catalytic agent. After long years of pioneering work by MGSN and with an enlightened approach by the government, a breakthrough point has been reached in the sanitation programme. User acceptance and use is satisfactory because villagers are prepared mentally before latrines are constructed.

Principal Gupta of Thapar Polytechnic presented a proposal which could be taken as a prototype for the kind of budget support required to achieve a breakthrough in the rural technology extension programme.

He suggested that to make an impact at least 1,000 chulahs and 100 latrines should be constructed in 100 villages in a state like Punjab, in one year. Only then could the idea catch on and the programme gain momentum, so that enough motivation is generated for replication.

If ten Janta-type bio-gas plants are constructed in ten villages, perhaps ten more would be motivated to build their own. Two community bio-gas plants based on night-soil could also be installed. These pilot plants could be used for running generators for electricity and for pumping water.

Financial Support Required

Subsidy per chulah (Rs. 5 from beneficiaries)	— Rs. 10	—10,000
Subsidy per latrine	— Rs. 100	—100,000

(50% of the cost should be made available to implementing agency so that they can utilise it at their discretion, rather than through the SFDA)

authorities or the BDO (as at present). Employment of full-time staff and field assistants to popularise the programme—Rs. 15,000 and concentrate on it.)

For gobar gas plants, no subsidy is at present available for the Janta model. Suggested subsidy—3,000 For community bio-gas plants 100 per cent subsidy would be required for pilot projects.

Support of district officials and BDO is essential for the success of the programme. It was suggested that VLWS and Gram Sevak Samities could be motivated to work along with the workers of the extension agency. The importance of building rapport with the people cannot be minimised—it is a pre-requisite for a successful programme.

Prad embarked on action research for Sanitation in the late fifties. Their design was developed and the important components were manufactured and sold at subsidised rates. Printed material in the form of pamphlets and posters were distributed to popularise the programme. PRAD masons were sent to each block to train the local masons. Work on the chulah was done in the sixties and similar steps taken to popularise it. Now PRAD is concentrating on bio-gas plants. The Janta bio-gas plant based on the Chinese model was developed in the seventies. Work is in progress on community gas-plants with 60 cu. mtr. and 30 cu. mtr. digesters.

Shri Bindeshwar Pathak of Sulabh International stated that Bihar State Financial Corporation had asked him to take up the job of implementing their target of building 5,000 latrines in one year, ten latrines per village. Rs. 200 would be available as loan and Rs. 200 as grant. Statistics show that 1 crore has been used up for 400 constructed and 10,000 under construction, but no names of latrine owners or specific villages could be obtained.

Sulabh International did not take up the offer as it did not feel that the programme was viable. Shri Pathak felt that if 1000 individual latrines and one community latrine (at the block office) was targetted for each block i.e. 20,000 latrines constructed in each district (?)—then the villages would be saturated, and the impact of the programme felt.

He suggested that training can be given to unemployed persons to construct the latrines and maintain them. Loans should be made available from the Rural Banks as a revolving fund for those taking up the programme, so that it becomes economically feasible for them.

GENERAL OBSERVATIONS

Addressing the Workshop at the concluding session, Mr. Handa (Ministry

of Education) pointed out that the government and his department had realised that technical institutions should interact with the environment and society. As a result, institutions situated in rural areas, have been identified as community polytechnics, which are to utilise their infrastructure, facilities and funds for taking tried and tested technologies to the field. The government has provided grants and appointed liaison officers for the purpose. Centres selected for appropriate technology also often have the means to manufacture and distribute the items on a large scale.

However, the ground has to be prepared in the villages to gain acceptance for the new technology. The first priority is increase in income for which employment generation is of utmost importance. Technologies which enhance availability of energy and water supply will therefore find ready acceptance, we felt.

At first, therefore, certain types of technology may have to be made available to villagers without any cost. Later, when they get accustomed to it, they will improve on it themselves.

Villagers, poor people, are naturally interested in bread and butter questions first. Therefore, their requirements must be assessed carefully before the introduction of any new technology.

Happily, to-day the different inputs required for carrying out this urgent and difficult task are available. Technical, management, development and voluntary agencies are all ready: what is needed is an integrated, cohesive approach towards a common objective. The missing factors like technological inputs, organisational efforts and integrated planning are being introduced. Certain corrective measures have been taken but the expected results have not been achieved yet. Perhaps a cohesive body is needed to work towards a common cause.

Technical institutes have been asked to provide the missing links and they can do so provided they are supported by social organisations and other agencies.

Here the concept of CART—Council for Advancement of Rural Technology—is a significant development. This body has been formed under the Sixth Five Year Plan to act as an umbrella organisation—to serve as a focal point and clearing house for development and advancement of rural technology. The objectives of CART are strikingly similar to CORT. It was pointed out that one role of CART would be to monitor activities of development agencies so that there was no undue duplication. However, it was

countered that sometimes more heads are better than one specially when the problem is a tough one!

It was stated that enough funds were available for good projects undertaken by dedicated people with a planned approach.

On the whole, representatives of the government departments and agencies showed interest and expressed support and concurrence for the aims and objectives of the Workshop. Because of the similarity of views, cooperation from the government side could be expected.

This is most important as reiterated by Prof. Batra of Thapar Polytechnic, who said that spade work can be done by the field agencies, but the multiplier effect will only be possible with the full support and help of the district authorities, the B.D.O.'s and VLWS.

The delegate from NBO stated that his organisation would be glad to collaborate in any extension and popularisation programmes like providing or making films, exhibitions, publications etc., with other extension agencies. He said that their Rajasthan centre had achieved best results so far as construction and acceptance of Chulahs and latrines went, while the Bangalore wing had carried out the maximum training programmes.

Shri Anant Rao pointed out that the receiving agencies at the village level had become inert and ineffective, thanks to the demoralising effect arising from postponement of elections etc. For successful implementation of these programmes, the village organisations have to be rejuvenated, so that they could actively participate and cooperate in the projects. If existing agencies could not be trusted fully to carry out their share of the tasks properly, new agencies could be formed for development purposes.

IV

Abstracts of Papers Presented at the Workshop

Paper Presented by Dr. K.C. Khandelwal—Specialist (Organic Fertilizer), Ministry of Agriculture, New Delhi.

The paper discusses the function of night-soil digesters from three aspects :

- 1 Fundamental
- 2 Public health, and
- 3 Practical

The composition and the potential of the methane gas is discussed in detail. This varies with the exact system of collection:

Possible uses of the spent slurry are described. It is pointed out that though the treated slurry may still contain viable helminth eggs, no practical method reduces pathogens in excreta as much as anaerobic digestion.

From the practical point of view the present need is to conduct case studies with a view to analyse constraints and find out solutions.

A conceptual plan for linking "Sulabh Sauchalayas" with fixed dome bio-gas plants is presented.

Sanitary Latrines and Smokeless Chulahs—by Shashi Kant, Asstt. Director, N.B.O.

The first part deals with sanitary latrines, their importance for health etc. and the constraints which prevent village people from adopting them.

The two pit leaching toilet is promoted by NBO through their Rural Housing Wings. Demonstration models have been set up in homes of prominent persons of village society.

The organisation is willing to collaborate in field surveys to study user acceptance, with a view to improving extension methods.

The section dealing with smokeless chulah examines the need and desirability of promoting this device from the point of view of women's health (specially eyes) and conservation of fuel.

A comprehensive study on chulahs was commissioned by NBO and carried out by PRAD.

The design with the optimum efficiency in fuel and time used, was chosen.

The improved PRAD 2-hole chulah with chimney was selected for promotion. This is done through the Rural Housing Wings and at fairs, exhibitions, etc. The model has had a good response.

NBO is interested in collaborating in any effort at popularising these items of rural technology.

**Excerpts from the HUDCO Working Paper Series
"Bio-gas-an Alternative Source of Energy—Y.K. Garg**

It is emphasised here that so far digesters based solely on night soil have not proved very successful. Problems of dilution and offensive odor of the slurry are pointed out. Plants based on dry conservancy system seem to be more effective.

An integrated plant fed by night soil, animal dung as well as agricultural wastes is suggested.

Experiments with digesters based primarily on agri-residues and those using household wastes in addition to night-soil, are described. Gas plants installed by individual households require a high capital outlay; community plants would be more economic. Tamil Nadu Housing Board has such a scheme.

Although bio-gas technology has been developed some time ago, certain constraints have hindered large-scale implementation, particularly among economically weaker sections.

Areas where research and development work is urgently required to remove these constraints are pointed out.

Challenges and Handicaps in Popularising Smokeless Chulahs Rural Latrines and Bio-gas plants by D. R. Gupta and V.S. Batra, Thapar Polytechnic, Patiala.

The paper points out that the community wing of the polytechnic was set up with a view to utilising its technological and managerial infrastructure in extending simple technology to rural areas.

Sanitary latrines and smokeless chulahs were chosen as appropriate technologies whose introduction would have a psychological impact on rural people.

The challenges and handicaps faced in introducing chulahs and the model being constructed by T.P. are discussed in detail.

Rural Latrines

The dry pit latrine is stated to have great potential in rural areas because of its simplicity and low cost.

The design and its functioning are described, along with the cost involved.

In spite of being inexpensive this is beyond the means of the poor. There is a good case for a high subsidy in order to popularise this technology which (which) will be beneficial to environmental health and an important means of modernisation of Indian villages.

The go-bar gas plants constructed by TP with the help of AFPRO are described. Villagers have shown interest in the technology while visiting the demonstration units. Funds and lack of cement have proved the biggest constraint in setting up gas plants in villages. Also no subsidy is available for the Janta model, which is a big handicap.

A national policy on bio-gas as well as clear identification of agencies in each State to take up installation/construction of go-bar gas plants is recommended.

Community plants should also be tried out.

Chimney Design for Domestic Kitchens: Dr. Ishwar Chand, T.N. Gupta and P.K. Bhargava (CBRI- Roorkee)

Elimination of smoke from the kitchen is most desirable from so many points of view. An optimised design for a chimney has been evolved at CBRI and is functioning well at the trial houses/sites.

The chimney consists of four components, viz (1) hood, (2) flue, (3) protecting cap and (4) wire mesh grating (Details of the design of each component are given along with the cost.

Summary of Report on Safai Vidyalaya, Ahmedabad, Gujarat

The emancipation of the scavenger class (Bhangi Mukti) was the incentive that first spurred the work of Safai Vidyalaya run by the Harijan Sevak Sangh.

Since that time, the organisation has been a pioneer in the sphere of sanitation in the widest sense of the term. Shri Appasabhib Patvardhan and Shri Krishnadas Shah provided the early leadership and inspiration for the programme. To-day Shri Ishwarbhai Patel is the driving force in the organisation.

In addition to various programmes for the welfare and emancipation of the sweeper community, the organisation is actively engaged in programmes of rural development with special emphasis on sanitation.

Conversion of dry latrines is a major focus of attention.

Village latrines, soakpits, bathing platforms, chlorination of wells, provision of smokeless ovens and ventilators—these are some of the other areas attended to under the programme.

Apart from the actual construction of these facilities the Vidyalaya also has a vigorous training and education programme to facilitate the extension work.

It conducts training courses, educates and guides workers of various constructive organisations as well as guiding municipalities, gram panchayats, in formulating their programmes. Exhibitions with charts and implements are arranged as well as conducting seminars, shibirs and conferences. Posters, pamphlets, publications of other relevant literature and slides and documentary shows are arranged.

The slogan of "Wealth from Waste" is carried to the villages where cultivators are taught the proper use and recycling of dung etc.

Training of teachers and students of Basic Education High Schools are arranged.

The government of Gujarat is actively supporting the rural sanitation

programme and takes the help of Safai Vidyalaya in organising orientation and demonstration camps for sanitary inspectors and extension officers, to prepare them for implementation of rural sanitation schemes.

The National Social Service Scheme for University Students incorporates rural sanitation work in its programmes.

Gujarat also has a Village re-organisation and rural house reconstruction programme under which construction or conversion of latrines and smokeless chulahs is undertaken.

The programme has now been re-oriented towards providing basic facilities to families in economically backward classes in order to improve their living conditions.

Financial details of the scheme are given.

In Gujarat, official and non-official agencies are interacting well together towards the objective of rural environmental sanitation and general development and reconstruction of villages.

The grant in aid for these programmes is 50 per cent people's contribution which can be reimbursed from the Panchayat's own funds raised by local taxation.

Where 60 per cent of the population belong to backward classes 25 per cent out of 50 per cent popular contribution is allowed to be contributed from the equalisation fund and the other 25 per cent is reimbursed from the Panchayat's own funds.

Rural Sanitation—A Report on Village Latrines—Jayanti Banerjee, Institute of Social Studies Trust

This is a review of research and action in India in the field of rural sanitation.

The declaration of the International Water Supply and Sanitation Decade has fortunately focussed attention on this little discussed and neglected topic.

Research on low-cost sanitary options are reviewed and government and non-government agencies working in this field are identified.

Different designs for sanitary latrines using intermediate technology, are described.

The background of the sanitation programme in India, pilot projects underway and current schemes in certain states are discussed.

The methodology of some successful schemes and certain agencies are studied: notably the Safai Vidyalay's work in Gujarat, Sulabh International's programme in Bihar and the Environmental Sanitation Programme in Kerala.

In summary, the current status of rural sanitation is highlighted and necessary components for a viable future programme are pointed out.

Planning Towards Improved Sanitation for all—Sequel to Report on Village Latrines—Jayanti Banerjee, Institute of Social Studies Trust

The latest position on the sanitation scene is briefly reviewed.

The United Nations initiative has borne fruit in the form of a detailed World Bank Report which offers some useful and interesting ideas and guided-sented neatly through a set of algorithms.

The Oxfam Sanitation Unit developed for emergency situations and used in Bangladesh refugee camps is discussed.

The recommendations of the Public Health Engineers' Conference held in December 1980, are stated.

Certain new agencies working in this field are identified.

It is found that considerable action has taken place in planning but implementation on a large scale is yet to reach the take-off point. It is observed that apart from the technical angle, there is great need for paying careful attention to the sociological aspect of sanitation programmes.

Cooking with Firewood—The Burning Issue—Jayanti Banerjee, Institute of Social Studies Trust

This is a status paper on smokeless economic chulahs. The drawbacks of the open-fire chulah commonly used by rural women are pointed out.

Research efforts in India on developing and popularising an efficient chulah are reviewed briefly. Several improved models are described.

The basic guidelines for proper use of these models are given.

Extension efforts in the past and the reasons for their failure are discussed. Some current programmes are described and the need for urgent research cum-action in this sphere is pointed out.

A Survey of Selected Sanitation Projects in India—A report for Oxfam—Shri D.K. Mishra

The paper starts with a review of sanitation planning in the past and proposals for the future. This is followed by a discussion of disposal systems currently in use in India—apart from the conventional sewerage system. Emphasis is on relatively low-cost options. The septic tank, bucket privy, PRAI-type leaching pits, Aqua-privy, manure pit latrines and some research trends in latrines are dealt with. Next, the author presents a survey of government and non-government agencies involved in sanitation work in India. The agencies listed are:

- 1 United Nations Development Programme (UNDP) Global project which covers 110 towns in 7 States.
- 2 Public Health Laboratory, Najafgarh, New Delhi
- 3 Agra Municipal Corporation, Agra
- 4 Rajasthan Institute of Local Self-Government, Jaipur, Rajasthan
- 5 Municipality of Udaipur, Rajasthan
- 6 Indian Institute of Public Health and Hygiene (IIPHH), Calcutta
- 7 Calcutta Metropolitan Development Authority (CMDA), Calcutta
- 8 The National Environmental Engineering Research Institute, (NEERI), Nagpur
- 9 Central Building Research Institute (CBRI), Roorkee, U.P.
- 10 Planning Research and Action Institute (PRAI), Lucknow, U.P.
- 11 Institute of Public Health, Poonamalee

VOLUNTARY AGENCIES

- 1 Maharashtra Gandhi Smark Nidhi (MGSN)
- 2 Malpatra Utpadan Kendra, Amraoti
- 3 Friends Rural Centre, Rasuliya, Hoshangabad, Madhya Pradesh
- 4 Seva Mandir, Rajasthan
- 5 Vidya Bhawan Rural Institute, Udaipur
- 6 Sarvodaya Samiti, Andhalgaon District, Maharashtra
- 7 Sulabh International, Patna
- 8 Safai Vidyalaya, Ahmedabad
- 9 Kalyani Lutheran World Service (LWS), West Bengal
- 10 Centre of Science for Villages, Wardha

- 11 Harijan Sevak Sangh, Kingsway Camp, New Delhi
- 12 Gandhigram Institute of Rural Health and Family Planning, Madurai
- 13 Harijan Sevak Sangha, Madurai
- 14 Shri Nawrekar, Gobar Gas Plant Specialist, Maharashtra

In conclusion it is pointed out that solving problems of sanitation should not be undertaken purely in technical or financial terms but also in behavioural and cultural terms.

The success of any sanitation programme is directly linked to the water supply situation.

The current trend is to give first priority to conversion of dry latrines and 2nd to new installations; the priority for the beneficiary usually is the availability of a subsidy irrespective of the time it takes.

Scavengers : With each sanitary latrine constructed a scavenger loses one client. Alternative remunerative employment within or without the municipality is his concern and priority. Any sanitary programme should give due recognition to the priority of every participant, apart from giving technical guidance, arranging training for personnel such as masons, plumbers etc. supervising overall maintenance (at least initial period), of creating a (core) team of workers for a future take-over or for working independently in other locations. The programme must be arranged so as to have a logical sequence of events. No one aspect of the problem can be dealt with in isolation.

Priorities on health and sanitation do not match the priorities of the probable beneficiaries in the rural areas. Any sanitary programme exclusive to the rural areas will have to bear the entire cost of construction logical with administration and extension work costs. Benefits of the programme will never reach the last man unless the entire community is adopted and adequate provisions are made for future maintenance.

A very cautious approach is warranted.

At present sanitation is a priority in India only to planners and health workers—but a matter of general concern for all. It is yet to become a priority to the last man-rural or urban. The author feels that the living conditions of the urban poor are more unhygienic than their rural counter parts. Therefore when a sanitary programme is designed, priority should be urban slums and not the rural areas.

Critical Information on Items Needed for Selection and Design of Sanitation Systems (World Bank Report)

Climatic Conditions

Temperature ranges : precipitation, including drought or flood periods

Site Conditions

Topography

Geology, including soil stability

Hydrogeology, including seasonal water table fluctuations

Vulnerability to flooding

Population

Present, and projected—number

Density, including growth patterns

Housing types, including occupancy rates and tenure patterns

Health status of all age groups

Income levels

Locally available skills (managerial and technical)

Locally available materials and components

Municipal services available, including roads, power

Environmental Sanitation

Existing water supply service levels, including accessibility and reliability, and costs

Marginal costs of improvements to water supply

Existing excreta disposal, sullage removal and storm drainage facilities

Other environmental problems such as garbage or animal wastes

Socio-cultural Factors

People's perceptions of present situation and interest in or susceptibility to change

Reasons for acceptance/rejection of any previous attempts at upgrading

Level of hygiene education

Religious or cultural factors affecting hygiene practices and technology choice

Location or use of facilities by both sexes and all age groups

Attitudes towards resources reclamation

Attitudes towards communal or shared facilities

Institutional Framework

Allocation of responsibility, and effectiveness of state, local or municipal institutions, in providing the following services:

Water

Sewerage, sanitation, street cleansing, drainage

Health

Education

Housing and Urban upgrading

Note : The priority between various items will vary with the sanitation options being considered; the list above indicates typical areas which should be investigated by planners and designers.

Selected Papers Presented at the Workshop

**EXCERPTS FROM THE HUDCO WORKING PAPER SERIES :
BIO-GAS AN ALTERNATIVE SOURCE OF ENGERGY**

Bio-Gas from Night Soil —

National Environmental Engineering Research Institute, Nagpur (NEERI) has developed digesters for producing bio-gas from night-soil. The night soil is homogenised into a slurry of about 5-8 per cent solids in the homogeniser and fed into the digester. The digested slurry from the night soil digester is withdrawn on to sludge drying beds and allowed to dewater and dry. The filtrate from the drying beds is further treated in stabilisation ponds:

The gas produced contains 60-65 per cent methane and 35-40 per cent carbon-di-oxide with traces of hydrogen sulphide. The calorific value of the gas is 5660 K Cal/m³ and can be utilised for cooking and lighting or running an engine.

The Bio-Gas plants working only on night soil have not proved satisfactory. There are many reasons for this. For instance, the night gas plants are likely to have excessive dilution of fermentation material if the WCs are connected without flushing tank, as large quantities of sludge comes inevitably along with the faeces, which results in imperfectly digested slurry with offensive odor. To make it more successful, the night soil has to be carried out by headload or extracted by use of vaccum tankers from pits, transferred into the closed movable tankers and then carried to the soil digester to keep the water content low and use the night soil from these areas for production of bio-gas.

The bio-gas produced from night soil alone is about one cubic meter per person per day. Mr. Desouza in Tamil Nadu, has installed a small city plant which is used by one family. The WC is attached to the digester and other organic wastes also fed. The bio-gas so produced meets the requirements of cooking for the family. Such plants can, however, be more successfully run, either with community latrines for hostels or common toilets are attached. The WCs are provided without flushing tank and connected directly to the digester. Small quantity of cow dung and other organic wastes are also mixed for increasing the production of bio-gas. This can meet most of the requirements of the community kitchen.

An integrated approach

The experiments at NEERI indicate that the gas produced from 100 per cent night soil is about 4 times the volume of that produced from 100 per cent cow dung on the basis of the volatile solids added.

Experiments also show that mixing of night soil with the cow dung producing bio-gas give encouraging results. Adding a latrine or two to the bio-gas plant working on cattle dung considerably helps in improving the fermentation by virtue of nutrient contents in the night soil and increase the quantity of gas and also the manure value of the outlet slurry.

An attempt has, therefore, to be made for integrating the bio-gas plant and the night soil digester. The completely integrated system has been schematically represented in the following sketch. (Fig. 1)

Use of Agricultural wastes for bio-gas

The experiments on using the agricultural waste as additive for producing bio-gas have also been tried. Agricultural wastes like gulmohar leaves, corn stalks, groundnut husk, bagasse and water hyacinth and sugars, cellulose, ammonium sulphate, cattle urine and fermenting slurry have been tried as additives to increase the production of gas. Though addition of agricultural waste do not increase gas production to any great extent but cattle urine and fermenting slurry does help in production of bio-gas.

In China, the main raw material used for digesters are agricultural wastes from paddy straw, wheat straw, green grass etc. The agricultural waste is mixed with human excreta and the cattle dung and crop waste and 50 per cent water. The pig droppings and human excreta accelerate the process of production of bio-gas. While the plants are mainly used for composting the agricultural waste, the gas produced is utilised mostly for cooking and lighting, stoves and lamps. Gas is also used for generation of electricity for running engines.

Bio-Gas from Human Settlements

Attempt is also being made for production of bio-gas in the housing colonies by using the night soil, raw garbage, saw dust, rice husk etc.

The basic problem for setting-up of bio-gas plants in housing colonies is that it has to depend largely on night soil and raw garbage as cow-dung is not available. From a housing settlement of 400 users 800 kg of night soil is available per day, added to this, 150 kg of raw garbage, 50 kg of saw dust

and rice husk, can produce 250 cubic metre bio-gas and 3500 gal. liquid effluent slurry. The best value of this gas produced would be equivalent to 7 Indian Gas Cylinders and will meet the cooking requirements of 750 to 1000 adults per day while the effluent slurry can be used for growing vegetables in the kitchen gardens. To reduce the amount of water in sewage all latrines will have to be fitted with pans minus flush out cisterns to keep the water content low. The addition of dairy and poultry units sized to meet the requirements of the housing Colony, will yield enough raw material to feed the digester.

The total bio-gas production will meet nearly 90 per cent of requirements of the community. Supply of solar-heated water to the gas holder and also to the community will increase the bio-gas production and can meet even 100 per cent of the cooking requirements of the housing colony.

Tamil Experience

The bio-gas plants if installed at individual level, need higher capital outlay and thus community participation is necessary to reduce the cost of gas production per family. Tamil Nadu Housing Board has undertaken a programme for setting up of a bio-gas plant for a group of dwelling units being constructed in their radial site and services scheme at Maraimalai Nagar near Madras. Small capacity plant for a group of 16 families is proposed at a cost of about Rs. 15,000 i.e. Rs. 850 per family which includes the gas distribution system (Fig. 2) The performance and advantage/disadvantage of the systems can be evaluated only after the bio-gas plant is installed and starts operation. Tamil Nadu State also proposes to set up such plants in its Rural Housing Schemes where a larger group is constructed. However, the project is yet to take off and the performance can be evaluated only when few of these plants are in operation for some time. However, there appears to be a possible use of gas produced by the bio-gas plants in the low income group and rural housing projects.

Looking Forward

Though the bio-gas technology has been developed much earlier, the main hindrance in the large scale use of bio-gas technology in housing projects particularly for economically weaker sections and low income groups, include:

- (a) High installation cost
- (b) Low life due to wear and tear
- (c) A sharp fall in gas production at low temperatures

- (d) Non-availability of enough raw materials and
- (e) Basically rural based and cannot be used in urban centres.

A lot needs to be done on research and development. (1) Large percentage of carbon di-oxide needs to be reduced either by biological control or by selective filtering out. (2) Designs for full-proof gas plants for night soil as the present pure night soil plants are not altogether trouble-free. (3) Large mass of solid vegetable refuse which, if composted, can also yield gas, but it does not lend itself to the present continuous system of digestion. Suitable batch type plants need to be evolved. (4) The outlet slurry is semifluid. In urban areas there is not enough land for drying the same. Some special method of dehydration has to be found.

BIOGAS FROM NIGHT-SOIL

K.C. Khandelwal, Specialist (Org. Fert.) Ministry of Agriculture New Delhi.

One of the methods of sanitary disposal of night-soil is anaerobic treatment. The feasibility of this process depends upon not only technical design of anaerobic digester (bio-gas plant) but also methods of collection of night-soil (including types of latrines, dilution, etc.), handling of spent-slurry, use of disinfectants for cleansing of latrines, etc. The specific approach to establishment of such a disposal system and its management will be conditioned by the location of the unit; economic consideration; psychological inhibition and resistance to use of biogas as cooking fuel and handling of spent slurry; commitment of the society to cooperation, etc. In the following paragraphs, the following aspects have been discussed in brief:

1. Fundamental Aspects
2. Public Health Aspects
3. Practical Approaches

1. Fundamental Aspects

The quantity of human excreta and urine per capita per day is about 200 g. and 1.0 litre respectively. Human excreta contains about 13 percent total solids. Since the optimum total solid concentration in an anaerobic digester is normally 7-8 percent, the proper level of dilution can be achieved by restricting the quantity of water for each ablution upto one litre only.

It is estimated that the yield of biogas is about 0.034 cu. m. per person per day ;at 27°C, i.e. 0.39 cu. m. per kg. total solids or 0.45 per kg. volatile solids.

The biogas generated from night soil contains on an average 65% methane, 34.9% carbon-di-oxide, 0.6% hydrogen sulfide and 0.4% other gases. The gas as such can be used as fuel for cooking and lighting purposes. However, removal of hydrogen sulfide, which is a corrosive gas, will be necessary before biogas is utilised for running of diesel engine. In case of bio-gas generated from cattle dung, the concentration of hydrogen sulfide gas is negligible).

Disinfectants used for cleaning of community latrines should not be allowed to enter in the digester. Otherwise, the gas production will be reduced or stopped.

Spent-slurry obtained from the digester has fertiliser value. Average chemical analysis of the spent slurry on dry weight basis is 3.0 to 5.0 percent N; 2.5 to 4.4 percent 1_2O_5 ; and 0.7 to 1.9 percent K_2O . The quantity of spent slurry produced will be 0.7 litre/capita/day. It can be used directly as manure for raising fodder and cereals and also for manuring of fish ponds. It can also be dried on simple sand beds and used for growing of different types of crops including vegetables. Another use is for hastening the process of composing of refuse and farm wastes in pits.

Night-soil digesters need desludging once in a year or two.

2. Public Health Aspects:

The potential hazards inherent in the process are at the following two stages (i) the handling of night soil for addition into the digester and (ii) use of spent slurry in crop and fish production.

The nature and variety of diseases that can be transmitted through improper handling can be viral (infectious hepatitis), bacterial (typhoid, bacillary dysentery, cholera, protozoan (amoebiasis) and helminthic (roundworm, hookworm) origin.

The published data on survival of pathogenic micro-organisms in anaerobic digesters have a wide range of values. It has, however, been demonstrated that pathogenic enteric bacteria are effectively killed off if the digestion time is at least 14 days at a temperature not lower than 35°C. It also results in a 22% enteric viruses die off. National Environmental Engineering Research Institute, Nagpur, has reported 66 to 90 percent removal of ascaris and hookworm. These studies, however, reveal that although digestion removes appreciable number of helminths, the spent slurry still contains viable helminth eggs. Nevertheless, there is no other practical method of treating human excreta that will reduce the burden of pathogens as much as

anaerobic digestion. A list of procedure could be drawn up that could effectively eliminate the dangers inherent in handling of human wastes.

3. Practical Approaches:

Presently, over 90,000 biogas units mainly based on cattle dung have been set up in the country. It has been found that about 5.6 percent more gas could be obtained if night soil from one person is digested along with the dung of one animal. Khadi and Village Industries Commission has reported that over 2500 such units have connections with latrines, mostly in the State of Maharashtra Gujarat and Karnataka.

Night-soil digesters have also been installed in the country. Two such plants handling the waste from 50,000 to 60,000 persons are stated to be in operation in Quilon and Trichur in Kerala. National Environmental Engineering Research Institute has set up a pilot plant at Central Prison, Nagpur. All these plants have steel gas holders which is reported to corrode within a few years possibly because of corrosion caused due to high content of hydrogen sulfide in biogas produced from night soil. Recently, Action For Food Production has set up a fixed dome cheaper biogas plant based on night soil at Midnapur, West Bengal. It would be desirable to conduct a case study on some selected plants. with a view to analyse constraints and find out solutions.

Conclusion

There is a good potential for setting up night soil biogas plants in villages and periphery of towns; wherever dry conservancy system exists. Night soil biogas plant should be considered as a method of sanitary treatment and disposal which allows recovery of fuel gas and manure. This method reduces the spread of intestinal diseases to a large extent.

While R&D efforts should be made to solve operational problems, such as methods of collection of excreta and urine and ablution water separately, dilution of excreta, use of disinfectants in cleaning of latrines, cheaper model of biogas plant, devices for mixing of content in the digester, gas production in winter, removal and use of spent slurry as manure, etc. associated with night soil biogas system, it should be possible to undertake pilot studies, for example with on-going 'Sulabh Shauchalaya' programme.

EXCERPTS FROM WORLD BANK REPORT/DECEMBER 1980

Appropriate Technology for Water Supply and Sanitation: A Summary of Technical and Economic Options By John M. Kalbermatten, De Anne S. Julius, and Charles G. Gunnerson.

This summary identifies the broad technical, economic, health and social findings of the research carried out and discusses the aspects of programme planning necessary to actualize the findings. Thus it is directed primarily to planning officials and sector policy advisers in and for developing countries.

Certain important passages and points from the summary are reproduced here.

For the purpose of this study, an appropriate technology is defined as a method or technique that provides a socially and environmentally acceptable level of service or quality of product at the least economic cost.

"The process begins by identifying all of the technological alternatives available for providing the service desired. Within that set there will usually be some technologies that can be readily excluded for technical or social reasons. Once these exclusions have been made, one is left with the range of technically and socially feasible alternatives. For these technologies, cost estimates are prepared that reflects their real resources cost to the economy. Least-cost solutions for each technology are selected. On the basis of these economic costs and discussions with Government planners, financial costs are prepared for all least-cost solutions. The final step in identifying the appropriate sanitation technology must rest with the eventual beneficiaries. Those alternatives that have survived technical, social and economic tests are presented to the community with their attached financial price tags, and the users decide what service level they are willing to pay for".

The main technical and environmental factors that are important in selecting sanitation technology are as follows:

- 1 Water Supply Service Levels.
- 2 Soil Conditions.
- 3 Housing Density.
- 4 Complementary Investments e.g. off-site treatment facilities.
- 5 Potential for houseowner Construction.
- 6 User Hygiene Habits.
- 7 Institutional Constraints.
- 8 Technical Evaluation-Technical Suitability of various technologies for application in a specific community.

The economic evaluation of alternative sanitation technologies comprises 3 components: comparable economic costing, maximizing the health benefit from each alternative through proper design and allowing the user to make the final benefit-cost determination.

The single most useful figure for cross technology cost comparison is the total annual cost per household (MACH). This includes both investment and recurrent costs, properly adjusted to reflect real opportunity costs, and average over time by the average incremental cost method. The use of per household rather than per capita costs is appropriate for those systems with on-site facilities designed for use in a single household.

Two important influences on total household costs which have usually been ignored in engineering analyses—are on-site household costs e.g. (internal plumbing) and the cost of flushing water for water-carried systems. The former is important in all cases and accounted for approximately 45% of total household costs on annual basis. The second point is important for water borne systems; where the economic cost of water is high, it is essential to design systems with low requirements of flushing water.

The fourth functional cost component is recamation. If re-use benefits can be produced they could off-sets some of the other costs. While there is much experimental and thortical data on the economic potential of re-use technologies, there is a dearth of empirical data derived from actual experience.

Besides the technical findings, the research has produced a new approach to the problem of linking health benefits to environmental sanitation improvements. It is recognized that quantifying the health benefits is not the primary objective of better sanitation—*achieving* them is.

Research teams have developed an environmental classification of excreta-related infections that, together with a basic understanding of factors important in disease transmission, enables the planner and engineer to maximize the health benefits of whichever technology is chosen. The means of doing so include both incorporating specific design features & supplementing the hardware with precisely targeted user education campaigns.—

It is realized that sanitation programmes will have little effect on incidence of infection-unless accompanied by sweeping changes in hygiene, major improvements in water supply and housing as well as major efforts in health education. The most important fact of excreta disposal for the control of these infections is the provision of a hygeinic toilet.

The importance of social and educational factors in the design and delivery of aptech—cannot be minimized. Social and culturaleal factors are of great importance in choice of alternatives or appropriate technology. The operational recommendation generally made is to increase community participation in the planning and selection stages in hopes that community responsibility can be generated to sustain the system during the operation and maintenance stages. The widespread failure of community water supply and latrine programmes, when measured by long-term successful operation or usage, points to the need for a more careful analysis of the socio-cultural aspects of technology choice and for more specific operational guidelines.

Three aspects of project design where social science inputs are very important—technology selection, etc., diffusion and adoption.

Low priority is given to sanitation needs in many communities: planning must link it with high-priority items. In rural areas, comunity involvement in planning water supply and sanitation projects usually requires the creation of an agency branch office accessible to consumers and with decision making power in project selection and development in line with policies and priorities established at the central office level.

The facilitators/extension workers should receive intensive training in the technical aspects of the technology and its promotion and they should have aids to help them.

When an appropriate organizational structure does not already exist at the community level, project participants should be expected to organize a locally selected committee to co-ordinate and oversee the community's contributions in the project.

Promotion should continue on a periodic or continuous basis long after projects are completed.

The preparation of appropriate sanitation projects, with its emphasis on community participation, training of local staff, and improvement or creation of institutions, will often require more time than that of conventional sewerage projects. They do, however, offer the opportunity to substantially expand sanitation service levels at modest cost.

The institutional and policy requirements for a successful (water-supply and waste) disposal programme are:

- 1 A sector strategy supported by Government;
- 2 Frequent reassessment of technologies;

- 3 A stable, autonomous institution with clear responsibilities;
- 4 A tariff policy that insures financial viability and encourages efficiency and equity; and
- 5 Manpower development programme and career opportunities in the sector.

Regional support offices for some communities—to provide guidelines and design assistance to local communities/monitor ongoing programmes and evaluate completed projects to ensure that lessons are reflected in new designs. They should maintain close liason among design, operation and maintenance activities and establish clear criteria for selection of materials and equipment.

It is important for institutions to have clear division of responsibilities. There should be no gaps or overlapping.

Rural communities need to develop a system they can operate and maintain with a minimum of external inputs. Usually this means local part-time management and operation with advice and assistance from a regional support organization.

List Of Participants

<i>Names/Addresses</i>	<i>Area of Interest/Work</i>
1. MR. H.C. SRIVASTAV Allahabad Polytechnic Allahabad	Appropriate Technology
2. MR. J.B. SINGH Director. Action for Food Production (AFPRO) C-17 Safdarjung Dev. Area New Delhi-110016	Agricultural and rural development. Specialises in water reservoir development, stock and agricultural development and building promotion.
3. MR. RAYMOND MYLES AFPRO	Appropriate technology related to rural and agricultural development. Specialist in Bio-gas technology
4. MR. NARENDRA VERMA Central Building Research Institute Roorkee-247 667	Sanitation and rural buildings. (e.g. farm buildings). Specialist in low cost housing construction technology and architecture. Central Building Research Institute has done a lot of work in the field of waste water disposal and use of paint to prevent corrosion. Has also done a study on leakage of Janata bio-gasplants.
5. MR. R. SETHURAMAN CPHEEO, Nirman Bhavan New Delhi-110001	Assistant Adviser to CPHEEO. His organisation is responsible for implementing the targets set for International Water Supply and Sanitation Decade in India.

6. **MS. MADHU SARIN**
Ford Foundation
48 Sector IV
Chandigarh-170001
Rural Development. Specialising in construction of smokeless chulahs
7. **SHRI RADHAKRISHNA**
Gandhi Peace Foundation
222 Deen Dayal Upadhyaya Marg
Delhi-110002
Chairman, Consortium on Rural Technology
8. **MR. Y.K. SHARMA**
Gandhi Peace Foundation
Officer Incharge, Library, Documentation and Information Retrieval Cell
9. **MR. V.M. ARAS**
Housing and Urban Dev. Corporation (HUDCO)
HUDCO House
Lodi Road
New Delhi-110003
HUDCO has carried out Rural Housing programmes. Mr. Aras is an architect who has specialised in housing design and development
10. **MR. Y.K. GARG**
HUDCO
Architect and Civil Engineer. Specialist in low-cost housing and use of new technology and materials for construction
11. **MR. L.C. JAIN**
Industrial Development Services Pvt. Ltd.,
M-1 Kanchanjunga
18 Barakhamba Road
New Delhi-110001
Fellow, Gandhi Peace Centre
12. **MR. KALYAN SUNDARAM**
Indian Cooperative Union
AIFACS Building
Rafi Marg
New Delhi-110001
13. **MR. GOPI KRISHNA**
Indian Cooperative Union

14. **MR. BHIM SEN SHARMA**
Development Officer
Khadi and Village Industries Commission
K-Block, Chaudhry Building
Connaught Place
New Delhi-110001
Mr. Sharma's field of work is bio-gas plants. He specialises in field extension
15. **DR. K.C. KHANDELWAL**
Specialist
Organic Fertilizer
Ministry of Agriculture
Krishi Bhavan
New Delhi-110001
The Ministry of Agriculture is carrying on a national project for bio-gas production. Dr. Khandelwal is a specialist in bio-gas, composting and bio-fertilizer
16. **MR. SASHI KANT**
National Building Organisation
Nirman Bhavan
New Delhi-110001
Dissemination of low-cost housing techniques, designing of rural and urban houses
17. **MR. A. RAMAN**
NEERI Zonal Laboratory
Chandrawal Water Works II
Lala Shamnath Marg
Delhi-110054
Environmental Engineering. Research in the field of rural and urban sanitation
18. **MR. P.T. NANJAPPA**
Development Engineer
National Research Dev. Corporation of India
61 Ring Road
Lajpat Nagar III
New Delhi-110024
NRDC is interested in promoting inventions, developmental projects appropriate to Indian conditions. Mr. Nanjappa is a specialist in marketing of technologies.
19. **MR. D.K. MISHRA**
Oxfam
A-81, Tayo Colony
P. O. Gamaria
Distt. Singhbhum
Bihar-832108
Oxfam's work involves low cost housing, sanitation and irrigation. It is a charity and developmental organisation and is exploring possibilities of assisting groups interested in taking up sanitary projects.
20. **MR. IBRAHIM**
Planning Research and Action Division
Kalakanka House
Lucknow-226001
Bio-gas psecialist. At present PRAD's work involves construction of Janata bio-gas plants in the field and training

21. MR. S.K. GADI
Public Health Engineering Dept.
Allahabad (U.P.)
Mr. Gadi is a specifilist in Public Health Engineering
22. MR. BINDESHWAR PATHAK
Sulabh International
Near Researve Bank
Patna-800001
Sulabh International is doing work in the field of sanitation, specially conversion of dry latrines.
23. MR. D.R. GUPTA
Principal
Thapar Polytechnic
Patiala
Specialist in smokeless chulah and rural latrine technology and also in the transfer of technology. He has written a paper on "Challenges and Handicaps in popularising chulahs and latrines and Janta Gobar gas plants.
24. PROF. V.S. BATRA
Head of Community Wing
Thapar Polytechnic
Patiala
Mr. Batra's work involves transfer to technology to rural areas
25. DR. SAM DALAL
UNICEF
UNICEF House
11 Jor Bagh
New Delhi-110003
Food and appropriate technology
26. MRS. JAYANTI BANERJEE
Institute of Social Studies Trust
Appropriate technology: Sanitation smokeless chulahs
27. MR. ALOKE N JHA
Institute of Social Studies Trust
Appropriate technology.
28. MS. MALINI CHAND
Institute of Social Studies Trust
Issues relating to women's development and welfare
29. MR. S.K. HANDA
Ministry of Education and Culture
Shastri Bhavan
Dr. Rajendra Prasad Road
New Delhi-110001
Education, Specialises in Technical education

30. MR. RAMA RAU
Khadi & Village Industries Commission
Bombay.
KVIC has sent up 80,000 bio-gas plants. Also involved in rural sanitation
31. MR. MANMOHAN DAYAL
Action India
C4/23 Safdarjung Dev. Area
New Delhi-110016
Mr. Dayal is a social worker. Working in the rural areas of South Delhi. He is a specialist in acrchitecture and planning.
32. MRS. SAVITRI MADAN
Maharashtra Gandhi Smarak Nidhi
Gandhi Bhavan
Kothrud, Pune
Mrs. Madan of MGSN is working in close association with KVIC. Among other things MGSN is working towards integrated development in Scheduled tribe areas and for Bhangi Mukti. Its work mainly involves rural sanitation and gas plant construction.
33. MR. GYAN SAGAR
Superintending Engineer
Jal Nigam, 6th Circle
C-279, Nirala Nagar
Lucknow-226007
Specialist in rural sanitation and water supply
34. MR. S.K. JAIN
U.P. Jal Nigam
M Project Division
C-279 Nirala Nagar
Lucknow
The U.P. Jal Nigam's work deals with getting bio-gas from night-soil, chulah (smokeless) and latrine technology. Mr. Jain is a Civil Engineer.
35. MR. T. VIJAYENDRA
Public Enterprises Centre for Continuing Education
6 Basant Lok
New Delhi-110057
The Public Enterprises Centre for Continuing Education has done work in the fields of appropriate technology and Labour studies. Mr. Vijayendra is a specialist on conditions of rural labour and labour in the informal sector. He is interested in sanitary latrines.
36. DR. ISHWAR CHAND
Central Building Research Institute (CBRI)
Roorkee-247667
CBRI's work involves building physics. Dr. Ishwar Chand specialises in building ventilation (e.g. in kitchen).

37. **PROF. P. D. KULKARNI**
Prof. of Civil Engg.
Technical Teacher's
Training Institute
Sector 26
Chandigarh-1600026
38. **DR. PHULRENU GUHA**
Karma Kutir
32 Baliganj Place
Calcutta-700019
Social worker
39. **MR. KUNAL DUTTA**
Gandhi Peace Foundation
Rural Development
40. **MR. ABIL KUMAR KARN**
Gandhi Peace Foundation
41. **MR. G. HANUMANTHRAO**
Mukkamalanai Street
Kannauarikota
Guntur-4
Andhra Pradesh
Holding of training camps for youths,
students, social workers
42. **SHRI ARUNACHALAM**
Chairman
Gandhi Nidhi
Delhi.

Specifications And Costs

NAIGAON SANDAS

Material required

Masonry Stone (Un cut)	—1 Brass
Bricks	—2000
Mettle Stone 3/4 "x"	—20 Cu. ft
Cement	—10 Bags
Full gate valve 2" diameter	—One Piece
Vent pipe AC 2" x 10'	—One Piece
Mild steel pipe 2" x 15" long	—One Piece
Latrine pan	—One Piece
Vent pipe cover 2"	—One piece
Door frame with 2 pieces wooden (Inside measure- ments)	—One piece
Mild steel Bars 10 mm.	—60 ft. length
A C sheet for roof 4' x 6'	—One piece

SOPA SANDAS : Y TYPE (2 Pits)

Material required upto Plinth Level.

Masonry Stone (un cut)	—1/4 Brass
Bricks	—1000
Cement	—2 Bags
Sand (Sifted)	—1/4 Brass
Latrine Pan	—One
Vent Pipe Ac. x 2" x 10'	—One Piece
Ac Pipe 4" x 3'	—One Piece
Ac Cowl 2"	—One Piece
Shahabad tiles rough 3' x 2' x 2"	—Four pieces.
Labour & Mason	—as per local rates.

Material required for super Structure

Bricks	—1000
Cement	—2 Bags
(Only for Pointing & plaster)	
Sand (sifted)	—1/4 Brass
Mud for construction	—1/4 Brass
Window 15" x 24"	—One Piece
Door frame wooden 6' x 2' With shutters	—One piece
(Inside measurement)	
Roof A C sheet 4' x 6'	—One piece

Cost Break-up of VIP Latrine Constructed by TP

Labour for digging	Rs. 20.00
Slab	Rs. 120.00
Pipe	Rs. 60.00
	<hr/>
	Rs. 200.00
For Brick jaali-100 Bricks	Rs. 250.00
S. Structure	Rs. 450.00
	<hr/>
Total	Rs. 900.00

Design : 4 ft. dia pit or 1.2 x 1.8 metres rectangle.
 3 metres deep
 R.C. Slab 3 inches thick and 1.5 metres square.
 6" dia. hole (15 cm)—for Vent pipe. 8-10 ft. (3 1/2m) long.
 5-7 years life.

Cost break-up for TP Chulah

4" dia A.C. Pipe of 5-7 ft.	Rs. 15
Set of M S rods	Rs. 3
	<hr/>
Total	Rs. 18
Mason's charges	Rs. 6
Bricks	<hr/>
These two items are provided by villagers, their expenses are normally not taken into account.	
All inclusive, cost would be	Rs. 60/-